



SECTION I: PROJECT SERVICES

Land Clearing, Restoration, & Well Pad Construction

SCHEDULE

Commencement Date: TBD

Date of Substantial Completion: TBD

DEL PROJECT TEAM

Director of Operations	Mark DeLancey
President of Operations	Jeff Kelley
Vice President of Operations	Greg Carter
Director of Health and Safety	John Carter
Project Manager	Boyce Long
I.T. Coordinator / Safety Coordinator	Rodney Shorette
Field Supervisor	Nate Putnam, Adam Forbes
Project EMT / Safety Coordinator	Dale O'Malley
Director of Site Security	Chris Kane

Contents

SECTION I: PROJECT SERVICES	1
DEL'S MAJOR EQUIPMENT LIST FOR PROJECT:.....	4
SECTION II: SITE AUTHORIZATION, RESPONSIBILITY & ACCOUNTABILITY	5
AUTHORIZED PERSONNEL:.....	5
ACCOUNTABILITY:	5
RESPONSIBILITIES:	5
SAFETY RESOURCES:.....	7
SAFETY CRITICAL TASKS	8
SHORT SERVICE EMPLOYEES PROGRAM:	9
RECORD KEEPING AND DISTRIBUTION:.....	10
EQUIPMENT MAINTENANCE AND INSPECTION PROGRAM:	10
SECTION III: EMERGENCY ACTION PLAN	11
BACKGROUND AND DUTIES:	11
REPORTING EMERGENCIES:	11
EVACUATION PLAN:	13
MEDICAL FACILITY MAPS & INFORMATION	16
SECTION IV: ACCIDENT PREVENTION	17
SECTION V: STANDARD OPERATING PROCEDURES AND SITE SPECIFIC RULES	27
SECTION VI: TRAINING	60
SECTION VII: HAZARD ASSESSMENTS and MITIGATION CONTROLS.....	62
Construction Process: ENVIRONMENTAL CREW	62
Construction Process: LOCATE CREW	63
Construction Process: UTILITY CREW	64
Construction Process: CLEARING CREW.....	65

Construction Process: MATTING CREW..... 66
Construction Process: R.O.W./GRADING CREW 67
Construction Process: TRUCKING 68
Construction Process: CLEAN UP CREW 69
Appendix A – Pipeline Restoration Plan 71

Rest of the page left blank on purpose

DEL'S MAJOR EQUIPMENT LIST FOR PROJECT:

To be filled in specifically for each project

Rest of the page left blank on purpose

SECTION II: SITE AUTHORIZATION, RESPONSIBILITY & ACCOUNTABILITY

AUTHORIZED PERSONNEL:

All assigned DEL and Sub-Contractor personnel shall participate in the Pre-Job Safety Meeting, and the Site Safety Plan shall be reviewed as to its location and contents, as well as other specific job rules and policies. After the Pre-Job Safety Meeting, participants will be authorized to participate in project activities.

ACCOUNTABILITY:

All DEL and Sub-Contractor personnel will be held accountable for their responsibilities as outlined in this plan. Additionally, disciplinary action including dismissal may be taken against any individual determined to have intentionally disregarded established safety rules and regulations including contents of the site safety plan.

RESPONSIBILITIES:

It is the responsibility of all assigned DEL and Sub-Contractor personnel to take all reasonable precautions for safety of site personnel and the protection of property from damage or loss. Specific duties and responsibilities are as follows:

Director of Operations shall be in charge of all daily operations of DEL and provide overall leadership in ensuring full understanding and implementation of the Health, Safety and Environmental (HS&E) Program plan.

Vice Presidents shall: Champion and support the health and safety program, and exhibit the safe behaviors they expect from their employees. They are responsible for providing and endorsing a current written HS&E Program and supporting the efforts taken to ensure program success. Communicate the importance of the DEL HS&E program to all employees and ensure that field management is accountable for internal and regulatory compliance.

Project Managers shall: Ensure designated Project Supervision is knowledgeable about the DEL and clients' HS&E program policies and standards. Ensure subcontractors are pre-qualified in compliance with DEL HS&E standards and all applicable governmental regulations. Communicate directly with owner/client management with respect to any HS&E issues and concerns. Participate in corporate and regulatory audits and periodic site inspections, reviewing project inspection reports and ensuring appropriate corrective action has been implemented in a timely manner. Participate in project safety meetings whenever possible and demonstrate a visible and professional HSE leadership role at all times.

Field Supervisors shall be responsible for ensuring implementation of all applicable safety rules and regulations including contents of this site-specific safety plan. These duties include, but are not limited to, the evaluation of equipment and resolution of any safety infractions requiring disciplinary action and coordination for accurate reporting of any accidents or incidents. Additionally, they are to ensure that HS&E hazards are managed at all times by performing ongoing safety inspections of the project. Field Supervisors must also accompany Government HS&E Inspectors/Officers during inspections and/or audits, ensure established safety and maintenance programs are followed for the safe operating conditions of all tools, vehicles, equipment,

lifting devices, mobile equipment and personal protective equipment (PPE).

Director of Health & Safety shall be responsible for ensuring all applicable safety rules and regulations are in place, understood and implemented by all personnel. These duties include, but are not limited to, ensuring the site HS&E plan is followed through on-site inspections, meeting with the primary and any sub-contractors to ensure their HS&E concerns are addressed and implemented as needed. The Director of Health and Safety shall ensure that site forman and field supervisors are following all requirements of the project HS&E plan and provide written updates to the Director and Vice-President of Operations.

Safety Coordinator will work with the Director of Health & Safety in implementing the HS&E plan and ensure all field personnel are aware of the requirements of the plan. The Safety Coordinator will report to the Director of Health and Safety on a daily basis.

Foremen shall be responsible and will be held accountable for the following:

- ◆ Ensuring all applicable safety rules and regulations including contents of this site-specific safety plan are followed. They shall ensure all employees of DEL are properly trained to meet job responsibilities and all safety task objectives.
- ◆ Complying with and enforcing all DEL HS&E standards as well as all applicable government regulations, laws and codes relative to HS&E compliance.
- ◆ Cooperating with the Health & Safety staff, including Safety Designates in regard to upholding the HS&E program, incident investigations, site inspections and our ongoing efforts to promote an accident free workplace.
- ◆ Coaching workers on DEL HS&E standards and regulatory compliance.
- ◆ Conducting "Safety Meetings" every day prior to the beginning of work and anytime the scope of work changes. The minutes of the meetings will be recorded on the prescribed Safety Meeting form, as well as confirmation of attendance. A copy of the meeting minutes form will be forwarded to the Field Supervisor for review.
- ◆ Ensuring hazards are identified and work stopped when hazards pose a risk to worker health or to the environment.
- ◆ Communicating to their respective workers on an ongoing basis, the potential hazards and required controls related to daily activities and ensuring that workers are given ample opportunity to provide input on hazards and suggestions for control.
- ◆ Performing ongoing inspections of work areas and implementing prompt corrective action for controlling any unsafe acts or conditions.
- ◆ Conducting accident/incident investigations on any undesired events that result in injury, property damage, refusal of work, or near miss with the potential to cause serious loss. Investigations may also include harassment allegations.
- ◆ Planning and cooperating with other project field management regarding the safe coordination of work being performed.
- ◆ Ensuring safety equipment and protective devices are provided and are properly used for each job.
- ◆ Providing direct supervision & observation to newly hired and transferred workers to ensure their work activities are carried out safely.
- ◆ Ensure established housekeeping standards are maintained.
- ◆ Providing a visible and professional leadership role in ongoing HS&E efforts.
- ◆ Assist in the development of the initial Job Site Analysis.

Sub-Contractors- shall be responsible for ensuring all employees under their control are following all applicable rules and regulations including contents of this site-specific plan.

Employees (DEL and Sub-Contractors)- shall be responsible for adopting a positive attitude toward safety through active cooperation and compliance with all aspects of this site-specific safety plan and other applicable rules and regulations. Additionally, all employees are responsible and will be held accountable for the following:

- ◆ Following the DEL HS&E program and taking an active role in protecting themselves and their fellow workers at all times.
- ◆ Reporting immediately, any hazardous conditions, unsafe practices, accidents or near-misses, injuries/illnesses to field management.
- ◆ Taking an active role in controlling project hazards.
- ◆ Providing suggestions to improve the HS&E program.
- ◆ Using all necessary Personal Protective Equipment (PPE) as well as any other required safety equipment provided.
- ◆ Informing attending physicians of our light duty/Modified Work program, in which DEL employees who become injured or develop an injury or illness as a result of a work-related event, are provide meaningful (full pay) employment during the rehabilitation period following a work-related injury/illness.
- ◆ Participating as required in accident investigations and completing all DEL HS&E forms as required as well as participating in corporate and regulatory HS&E (Health, Safety and Environmental) program audits.
- ◆ Refusing any assigned work that he/she believes is unsafe or poses a risk to health, safety and environment.
- ◆ Attending orientation safety sessions prior to performing any work.
- ◆ Ensuring co-workers are advised of unsafe conditions or acts that may cause injury or illness. If needed to protect personnel from imminent danger, are authorized to stop work.
- ◆ Demonstrating a professional attitude towards all corporate and project HS&E efforts

To this end, every employee is responsible for:

- ◆ Proper and safe planning of all work.
- ◆ Practicing safe work habits in every job undertaken.
- ◆ Promoting safety for their overall well-being and that of the coworkers.
- ◆ Practicing good housekeeping.
- ◆ Actively participating in all safety and JSA meetings
- ◆ Proper and safe utilization of all tools, equipment, and personal protection equipment.
- ◆ Reporting of any and all safety deficiencies observed to their immediate supervisor.
- ◆ Immediate Reporting of all work-related incidents, injuries or illnesses to their immediate supervisor.
- ◆ Reporting for work both physically and mentally prepared to handle all their responsibilities.

SAFETY RESOURCES:

Creating a safe workplace for every DEL employee, contractor and visitor is more than just the right thing to do it's critical to the success of our business. It is our mission to continually strive towards improving the safety of the workplace, to ensure our employees are able to return to their families in the same or better health than when they left them, and to protect the public and the environment from harm associated with construction activities. In an effort to accomplish this vision, DEL retains a staff of full time, professional health and safety specialists.

Director of Health and Safety (Corporate): The Director of Health & Safety is an upper-level employee assigned to manage the DEL Health & Safety program. This individual reports directly to the VP of Operations but works closely with the Director of Operations. This individual is responsible for managing a qualified and professional support staff, and providing direction in regards to carrying out the mandates of the HS&E

program. To maintain an effective HS&E Program, he/she is also responsible for assisting in the development of:

- ◆ HS&E program policies and standards.
- ◆ Job procedures and safe work practices.
- ◆ Training programs.
- ◆ Job specific requirements.
- ◆ Providing technical support in regards to:
 - ◆ Compliance with government regulations.
 - ◆ Standardization of processes and/or equipment.
 - ◆ Safety related statistics and identifiable trends.
 - ◆ Ongoing safety initiatives.
 - ◆ Developing, implementing and maintaining a comprehensive system for auditing DEL clearing operations and services.
 - ◆ Assisting executive management with the administration of the HS&E program by:
 - ◆ Reviewing formal inspections and accident/incident investigations.
 - ◆ Coordinating with management in follow-up activities.
 - ◆ Corresponding with government agencies as required.
 - ◆ Developing and implementing a comprehensive program for evaluating and monitoring HS&E compliance in regard to contracts and sub-contractors.

Construction Safety Officer (CSO): DEL will appoint a full time site CSO (Construction Safety Officer) to the project. The CSO will report directly to the Director of Health and Safety for DEL and will be responsible for identifying hazardous conditions and/or practices and implementing a corrective action plan to mitigate the hazards. This individual is also responsible for implementing the project Site-Specific Safety Plan, evaluating the effectiveness of the prescribed hazard controls and developing action plans to correct any noted deficiencies. Additionally, the CSO is responsible for communicating with the client HS&E representatives regarding any concerns and taking necessary action to address those concerns. He/she must also ensure all DEL HS&E policies, posters, rules and regulations are posted and assist the project management staff with investigations, analysis and completion of accident/incident reports and summaries. They are responsible for ensuring all required HS&E reports and meeting minutes are filed and copies are sent to the appropriate personnel and conducting formal (documented) project inspections weekly or when the scope of work changes. If necessary, additional safety personnel will be assigned to the project to help manage the health and safety program.

Site Safety Representative/Coordinator: DEL will appoint a full time SSR to this project. The SSR will report directly to the CSO representing DEL for this project, and will be responsible for identifying hazardous conditions and practices and assisting in corrective action to mitigate the hazards. The individual is also responsible for monitoring, coaching and teaching the Site Specific Safety Plan and reporting weakness and deficiencies to the CSO. An SSR will monitor each location where a crew is working. This will be a collateral duty that may be assigned to the foreman or his/her delegate.

SAFETY CRITICAL TASKS

Administrative: Site safety representation shall track the following: Personnel on site, qualifications, training, incidents and accidents, and other documentation. Tracking and trending of behaviors and conditions along with statistical reporting shall also be done.

Reporting: DEL shall report to the Director of Health & Safety each month: Hours worked, miles

driven, hours and number of individuals participating in safety training, number and description of accidents and incidents, and status of any injured employees.

Notification of an accident, incident, or near miss will be made as soon as reasonably possible but not to exceed 24 hours of the occurrence, with an invitation to the customer/customer representative to participate in the investigation. Regular update pertaining to developments of the incident, follow up action steps and additional information will be provided in a prompt manner.

Initial Job Site Analysis Development: The Initial Job Site Analysis ("JSA") is a working document, which is continuously revised as the job scope changes. All employees are active participants in the development and revision process with the foremen leading and safety staff technically advising and documenting (See Section VII). JSA's will be conducted daily and anytime the scope of work changes or conditions warrant.

Employees will receive training for new JSA's via documented safety meetings and/or site briefings. The respective JSA meeting documentation will remain on-site with the foreman throughout the course of the day for which it was completed. Upon completion of the day's activities, the foreman will then turn the JSA documentation into the on-site safety department prior to work commencing on the following day. Copies of all JSA's will be maintained in the project field office and originals will be sent to the corporate office for review and filing.

Inspections and Audits: A daily safety inspection will be completed and documented by an on-site safety representative to ensure compliance with the site specific safety plan. The safety department will analyze the reports in an effort to track and trend behaviors and conditions. Weekly a safety audit will be completed for each crew and supplied to the Director of Safety and Health to allow tracking, trending, statistical analysis and reporting. A formal site safety inspection/audit will be conducted bi-annually by a member of the corporate safety department. DEL will cooperate and encourage customers and their representatives to inspect and audit the project as needed to assist in promoting and assuring safe performance.

SHORT SERVICE EMPLOYEES PROGRAM:

Purpose:

This application applies to all pipeline clearing projects, station sites and job sites. The field supervisor will assure that all Short term Service Employees (SSE) will attend an orientation, receive training on safety and the work being done with qualified personnel.

Definitions:

Short Service Employees (SSE)- Company and/or contractor employee with less than 6 months in the same type of job and/or employment with the employer.

SSE Mentor- Each SSE shall be assigned a mentor. The mentor shall be an employee with 1 year of experience working on company locations.

Training:

- ◆ The Field Supervisor shall insure that each SSE is properly trained in:
- ◆ Hazards present on the job site.
- ◆ Procedures, processes and PPE developed to prevent these hazards from causing injuries, property damage and/or environmental incidents.
- ◆ DEL Safety Program.

- ◆ Skills necessary to conduct assigned jobs safely and efficiently while providing product quality and economy.

The Field Supervisor shall insure that each SSE is orientated to this program concept before starting work when:

- ◆ Employee is first hired.
- ◆ Employee is appointed to a new job assignment.
- ◆ Employee is exposed to new substances, processes, procedures, equipment, etc. that represent a new hazard to the employee.

General Requirements:

All SSE's are required to wear a Green SSE DEL' hard hat while on the jobsite, facilities when not in the office, break room, enclosed vehicle or restroom .

SSE Orientation:

The SSE shall be briefed at a minimum on the Company's procedures , rules and policies as outlined DEL HS&E manual. The training shall be documented. The following topics will be discussed but not limited to:

- ◆ DEL Safety Program.
- ◆ PPE.
- ◆ Jobsite protocols.
- ◆ Operator Qualifications.
- ◆ Known Hazards as discusses in the JSA.

Mentoring Requirements:

Mentoring is considered as transferring of skills and knowledge from mentor to employee. Mentors are to be volunteers, however a person can be chosen to perform as a Mentor, based upon that person's safety and work record.

The SSE is to be mentored for at least one month or longer, at which the SSE can be deemed to work safely and to be able to follow all provisions outlined in the program. New hires are labeled as an SSE for a minimum of two months depending on their background/experience. The SSE shall work under the direction of experienced employees or mentors.

All Mentors shall commit to the following:

- ◆ Be willing to watch a SSE perform a job without interfering as long as the SSE is not placing themselves or others in danger or potentially hazardous situation(s).
- ◆ Be able to coach and teach the SSE work rules about applicable safety practices as they pertain to the assigned tasks.
- ◆ Be able to provide positive feedback/reinforcement.

RECORD KEEPING AND DISTRIBUTION:

A file will be maintained of all SSE assigned to the workplace detailing qualifications and training. The foremen shall submit a copy of this documentation, to the safety department. Forms and statistics shall be maintained at the corporate headquarters in Middlebury, Vermont for at least one year.

EQUIPMENT MAINTENANCE AND INSPECTION PROGRAM:

The following program is to ensure that equipment used on the job is in safe operating condition before it is

put into service for the day. Equipment will be serviced and maintained as required by the manufacturer to assure good performance and long life.

The following Inspections will be completed:

Daily Inspection:

A daily inspection shall be completed by the operator of that piece of equipment before the equipment is put into service. This inspection shall cover critical points and shall assure these points are within manufacturers specifications, customer requirements, known hazards are eliminated, and DEL requirements are met. These inspections shall be documented and filed on site or at corporate headquarters.

Monthly Inspection:

A monthly inspection shall be completed by the site master mechanic or their designate. This inspection shall cover all essential operating functions of the equipment, and shall assure these points are within manufacturer's specifications, customer requirements, known hazards are eliminated, and DEL requirements are met. This inspection shall be documented and filed on site until the end of the project, or at the DEL Corporate office in Middlebury, VT.

Annual Inspection:

An annual inspection will be performed on equipment as required. This inspection will be documented on the required forms along with supporting documentation and kept on file at the DEL Corporate office in Middlebury, Vermont.

SECTION III: EMERGENCY ACTION PLAN

BACKGROUND AND DUTIES:

During the course and scope of the project, there is the potential for a number of emergencies. These include serious injury, fire, spills, evacuations and similar situations.

All DEL and Sub-Contract Personnel shall review this plan as follows:

- ◆ During Pre-Job Safety Meeting.
- ◆ When Responsibilities and actions under the plan changes.
- ◆ When written changes in the plan occur.
- ◆ And periodically during the construction schedule.

REPORTING EMERGENCIES:

Once an incident occurs, care and treatment of the injured party is the first priority. The incident will fall into one of three classifications: Medical Treatment, First Aid Only, or Near Miss. Follow the steps for the different types of incidents. These requirements apply to all personnel on client premises and property (i.e. Sub-Contractors). The client will be notified as soon as possible and within 24 hours of the incident with the basic information on the incident. This will be followed up by an incident investigation. The following actions shall be undertaken:

Near-miss:

- ◆ Event immediately reported to Field Supervisor.
- ◆ Safety Department is contacted.
- ◆ Employee involved fills out Near Miss Report.
- ◆ Supervisor investigates event.
- ◆ The safety department will determine the potential causal factors and fill out the DEL Incident

Investigation Report. Please note that the DEL Incident Investigation Report is all encompassing; it is to be used for any type and all incidents or events regardless of severity.

- ◆ Field Supervisor takes corrective action (i.e. corrects the problem, holds safety meeting to discuss awareness of situation and corrective action).
- ◆ Depending on severity of near-miss, DEL may require involved parties to submit to Post-Incident drug and alcohol testing.
- ◆ Report near-miss event to host employer.

First Aid Only:

- ◆ Care for injured party.
- ◆ Incident is immediately reported to Field Supervisor.
- ◆ Injury assessed by safety personnel or emergency conveyance vehicle attendant.
- ◆ Safety department and injured party fills out Incident Investigation Report.
- ◆ Field Supervisor completes investigation immediately to determine facts of incident.
- ◆ Field Supervisor reports findings to the Project Manager. Project Manager signs off on COMPLETED incident report and it is sent to the Corporate Safety Department.
- ◆ Field Supervisor takes corrective action (i.e. corrects the problem, holds safety meeting to discuss awareness of situation and/or corrective action).
- ◆ Safety Department reviews the incident report. Client is contacted if further clarification is needed.
- ◆ Safety Department follows up with employee on injury status.
- ◆ HS&E Director reports all incidents to Senior Vice President of Operations.
- ◆ HS&E recommendations are passed on to all field locations in the form of safety alerts or meeting minutes.

Medical Treatment:

- ◆ Care for injured party
- ◆ Incident immediately reported to Field Supervisor.
- ◆ Injury assessed by Field Supervisor and/or qualified First Aid personnel.
- ◆ If life threatening, supervisor or site personnel contacts Emergency Medical Services for immediate evacuation to the nearest Emergency Medical Facility (refer to ERP Maps contained in this plan) if possible. Field Supervisor contacts Safety Department.
- ◆ If condition is not life threatening DEL Safety Department is to be contacted.
- ◆ If possible, employee will fill out incident report with the safety department prior to being evacuated.
- ◆ If employee cannot fill out report, Field Supervisor will assist in investigating the incident and provide information to fill out the report COMPLETELY.
- ◆ Field Supervisor completes investigation immediately to determine facts of incident.
- ◆ Field Supervisor reports findings to the Project Manager. Project Manager signs off on report and it is sent to the Corporate Safety Department.
- ◆ If necessary, Field Supervisor and/or Project Manager take corrective action (i.e. corrects the problem, holds safety meeting to discuss awareness of situation and/or corrective action).
- ◆ Once employee is treated, DEL Management meets with physician to determine working status. If employee cannot return to regular duty, light-duty options are explored.
- ◆ If employee cannot return in any capacity, DEL Management meets with physician and employee to plan course of treatment to minimize time away from work.

NOTE: The guidelines are not intended to be a complete procedure for any of the three incident classifications. Many different conditions may warrant deviation from this policy. If at any time you are not sure what to do, contact the DEL Management.

ALWAYS REMEMBER.

Maintain position of the injured.

Keep the injured people lying down. NEVER move the person (especially the head and neck) unless you can clearly see immediate danger is certain. By moving the injured person, you may hurt them even more.

Call for HELP.

Always contact a Field Supervisor immediately for help. Send someone to bring EMT to the injured if needed.

Examination.

Initial assessment should focus on Airway, Breathing and Circulation Look for extensive bleeding or stoppage of breath. Personnel trained in FIRST AID should start the necessary emergency treatment until further help is obtained.

Remain Calm.

Most serious construction injuries do not require you to wildly rush the injured person to the hospital. It is important to reassure the injured person. Never move the injured person unless further damage is evident or you know what to do. Keep the patient warm but not hot. Send someone to get a Field supervisor.

EVACUATION PLAN:

Whenever an imminent danger or actual emergency situation arises, and it is determined that personnel must be evacuated from the project, the Project Manager will initiate the evacuation process. In an emergency, all persons are to be evacuated from their work area and shall assemble/meet in predetermined, designated areas.

Emergency Conveyance Vehicle: The emergency conveyance vehicle is not intended to be an ambulance and therefore shall not be equipped as such. This vehicle is to be utilized to transport employees who become injured or ill on the job site; however, only employees who remain conscious and are able to be safely moved, are to be transported to the nearest medical facility via emergency conveyance vehicle (refer to the section titled "Medical Facility Maps & Information). All others shall be transported via professional medical transportation services. The emergency conveyance vehicle shall be available during all hours of work and strategically located to allow the best support to the majority of employees.

The Emergency Conveyance Vehicle is a management asset and therefore is only dispatched by the Project Manager or the safety team. All requests for the emergency conveyance vehicle shall go through one or all of the above named entities. Should an instance occur where the emergency conveyance vehicle is requested in two or more places, priority will be given to the most serious situation which will be decided by the project Project Manager. In any situation where the injured party requests that professional medical transportation be contacted, or the attending personnel feel that professional medical transportation is justified, 911 emergency services must be contacted immediately.

The following explains the requirements of the Emergency Conveyance Vehicle:

- ◆ A vehicle that has four-wheel drive capabilities to allow access to remote areas of the project Right-Of-Way.
- ◆ A vehicle that has an enclosed area large enough for a conscious injured or ill person to be positioned as needed for safe and effective transport.
- ◆ The vehicle shall be equipped with a Level 2 Trauma Pack, a blanket, Fire extinguisher, stretcher, and backboard, C-spine, two forms of communications (cellular phone and two-way radio) and a copy of the Emergency Action Plan.
- ◆ At least two people shall be in the vehicle with the injured or ill person. One shall drive and be focused on that task while the other individual that is adequately trained and certified tends to the injured or ill person.

Note: Each crew consisting of ten (10) or more people shall have at least one person trained and

DEL Enterprise
currently certified in First Aid and CPR in case of Emergency.

ACCIDENT & INCIDENT CHECKLIST FOR FIELD PERSONNEL

"WHAT DO I DO?"

1. **PEOPLE FIRST!**: Protecting the health and safety of employees and other people who may be in there an is our number one priority. If necessary call 911 immediately and if hazardous materials are involved, be sure to inform the 911 operator. If a utility is involved notify them next.
2. **SECURE THE AREA**: Keep unauthorized people away from the site. Evacuate buildings and/or the site if necessary. Wait for public safety officials to decide when it is safe for people to return.
3. **CALL DEL COMPANY MANAGEMENT**:

During office hours, contact: Jeff Kelley, Senior VP 802-349-5463

After hours, or if they are not available at the office, contact a superior DEL employee.

Be prepared to provide some or all of the following information:

What happened?

When did it happen?

How did it begin?

Were there injuries or fatalities?

Was there property damage?

Is the event over?

News media? How many? Nature if inquiries?

4. **EMPLOY THE ATTORNEY CLIENT PRIVELEGE**

Make certain that any and all written report or pictures, in any form, are sent to the Chief Legal Officer and are captioned as follows:

"PRIVILEGED AND CONFIDENTIAL"

5. **AVOID DISTURBING THE INCIDENT SCENE**

- If possible, take photographs collect names and contact information for any witnesses.
- Document efforts to satisfy all safety standards.
- Prepare a time line of significant events leading up to and following the event.

IF CONTACTED OR QUESTIONED BY REPORTERS:

Communication outside of our company is the responsibility of designated company officials whose response to the media and other outside interests have always been prompt, honest and informative. In response to media inquiries, the Director of Operations, Senior VP of Operations & Chief Legal Officer serves as DEL CORPORATE SPOKESMAN and is responsible for representing the company in front of the media or any other attorneys. All media-related inquiries are to be routed through Senior VP of Operations at 802-349-5463.

UNLESS SPECIFICALLY DESIGNATED BY MANAGEMENT AS THE TEMPORARY, ON SCENE, CORPORATE SPOKESMAN, you are not expected or authorized to talk to the media, lawyers or other outside agencies on behalf of DEL.

If a supervisor is present refer questions to him. If the project owner or general contractor is responsible for the site, respectfully refer reporters to them.

IF MANAGEMENT DESIGNATES YOU AS THE TEMPORARY, ON SCENE, CORPORATE SPOKESMAN (pending the arrival of the CORPORATE SPOKESMAN),

- DO tell them you are the Temporary On Scene Corporate Spokesman pending the arrival of the Corporate Spokesman.
- DO tell them that the situation is being investigated and the company will provide more information through the Corporate Spokesman as it is available.
- DO express the company's concern for any injured people, deaths or property damage.
- DO stress the company's emphasis on safe operations
- DO let company headquarters know about any contact made with news media.
- DO NOT say "no comment". The best practice is to say: "I would like to refer that and all other questions to our Corporate Spokesman who is presently en route to this site. Once he arrives at the site and is briefed, he will be available to provide further information to the media."
- If questions persist, repeat this statement.
- DO NOT discuss liability issues or what may have caused the incident.
- DO NOT speculate about anything.
- DO NOT admit guilt.
- DO NOT talk "off-the-record"; even casual conversations may end up in print or broadcast.
- DO NOT let anyone else speak on behalf of the company.

6. IF GOVERNMENT INVESTIGATORS ARRIVE ON THE SITE:

- Politely ask for official identification.
- Obtain office and mobile contact information.
- Determine what information and access they are seeking.
- Tell them of the company's efforts to preserve and protect evidence.
- Promise all appropriate cooperation and ask how the company can be of assistance.
- Relay this information immediately to the Senior VP of Operations or another member of the crisis communications team.

DO NOT:

- Attempt to impede the investigation.
- Admit liability or speculate as to the cause(s) of the incident.
- Move equipment or evidence without the permission of authorized officials.

MEDICAL FACILITY MAPS & INFORMATION

Additional maps and information will be inserted once contact has been established with each medical facility. This will be completed prior to the start of the project.

SECTION IV: ACCIDENT PREVENTION

Accidents can be prevented by following the rules. All DEL personnel and Sub-Contractors are expected to review the rules below and apply them in performing any given task.

JOB ATTIRE AND PERSONAL PROTECTIVE EQUIPMENT (PPE):

Employees shall always be properly clothed. Employees are required to wear full-length pants, either long or short-sleeved shirts, steel-toed boots with a minimum of 6 inches of ankle support, Side Impact Type II hard hats, and ANSI Approved eye protection.

The outer most layer of clothing must be flame resistance clothing (FRC). An exception to this is when other personal protective clothing is required (e.g. welders leather). FRC must be worn with the sleeves rolled down, fully zipped and buttoned up. External garments such as rain gear and reflective vests shall be made of flame resistant material. Clothing comprised of synthetic blends (nylon, polyester, rayon, or polyethylene) shall not be worn under FRC. All undergarments must be made of natural fibers such as cotton or wool.

Loose clothing and loose jewelry shall not be worn when working around moving machinery. Clothing that has been contaminated by a potentially hazardous (flammable or toxic) material shall be removed as soon as possible and not worn until the clothing has been cleaned. Hair long enough to be potentially hazardous while working around moving machinery or rotating tools and equipment shall be secured. Hairstyles that make it impossible to properly wear a hard hat are not permitted.

Any employee encountering hazardous conditions must be protected against the potential hazards. The purpose of protective clothing and equipment (PPE) is to shield or isolate individuals from chemical, physical, biological, or other hazards that may be present in the workplace. If any employee finds that improvements can be made, please contact the DEL' Health & Safety Department.

CSA Type II Hardhats, Type II Class II safety vest, Safety Glasses - with approved side-shields (employees with prescription glasses MUST wear approved side shields) - and Steel-Toed Safety Boots shall be worn at all times while in work areas. Additional PPE may be required, depending on the hazards.

Conditions requiring additional PPE:

1. Gloves will be worn anytime materials being handled have sharp edges or present a hazard to hands, i.e. wire ropes or timber skids.
2. Double eye/face protection consisting of approved safety glasses and face shields will be worn during operations where the potential for eye and face injury has been identified during the pre-job hazard review. (Examples: cutting, grinding, sandblasting, chain sawing, hydro blasting, etc.)
3. Crew members will wear dust masks while performing mud-mixing operations.
4. Hearing protection will be worn in areas identified as being above 85db, (Grinding, hammering, welding, drilling or around high noise equipment.)

BEHAVIORAL JOB SAFETY ANALYSIS:

DEL intends to take a proactive approach to incident prevention that focuses on at-risk behaviors that can lead to an incident and on safe behaviors that can contribute to incident prevention. This is the meaning of behavior-based safety. Instead of being responsible for incidents, DEL encourages managers to be responsible for creating an incident prevention process.

PROPER LIFTING:

Lifting is an everyday part of your job routine. Every day you risk injury from strains, sprains and hernias. You can minimize this risk by learning to lift properly. Follow these simple rules:

1. Always size up your load. Get help for bulky and heavy loads. Employees should not lift more than 50 pounds without assistance.
2. Inspect your path of travel. Choose the safest (not the shortest) route. Be aware of tripping and/or slipping hazards.
3. Never lift with a rounded back and straight legs. Squat down close to the load, keep your back straight and lift slowly with leg power. When setting the load down, reverse the lifting procedure.
4. Never lift from an unbalanced position.
5. Shift your feet; don't twist around with a heavy load.

HOUSEKEEPING:

Housekeeping is the first law of accident prevention and each and every person on the job is responsible.

1. All stairways, scaffolds, ramps, platforms, walkways and work areas shall be kept clear and clean of trash and material.
2. Each employee shall be responsible for good housekeeping practices.
3. Put trash into the proper containers. Never throw scrap material or trash on the floor or ground.
4. Trash containers must all be equipped with "handholds" if they are to be manually lifted.
5. Clean up all oil spills and leaks promptly. If you must leave the area to get equipment to clean up the spill, have someone stay in the area near the spill.
6. Exits shall be kept free of obstructions.
7. Keep aisles and walkways clear of material.
8. Keep slings, wire rope, and steam and water hoses stored in racks if provided or neatly coiled out of walkways.
9. Return all tools including brooms, mops, and hoses to their proper place when finished with them. The job is not complete until all unnecessary materials are removed.
10. Before throwing broken glass in the trash, wrap it up to protect others from injury.
11. Never leave protruding nails in boards, boxes, barrels, or kegs. Pull nails out or bend them flat.
12. Keep your work area clean. Your work residue may not be a threat to you, but it may be to others in the area.
13. Store clothing and other materials in lockers or areas provided for that purpose.

FIRE PREVENTION AND CONTROL:

1. Gasoline and other flammable liquids shall be stored in a safety can that meets OSHA requirements and that is properly labeled with its contents.
2. All equipment shall be shut off before attempting to refuel it.
3. There shall be **NO SMOKING** except in designated areas as assigned by the Project Manager.
4. There shall be **NO SMOKING** or open flame in the vicinity of a refueling area. A fire extinguisher shall be readily available at each refueling area.
5. All gravity-fed fuel tanks shall be equipped with self-closing valves.
6. Fuel storage areas shall have a dike to contain accidental spills.
7. All fuel containers must be labeled to show its contents.
8. Fuel and oil spills are to be cleaned up immediately.
9. Never use gasoline for washing parts. Use an approved solvent with a flash point of at least 140° such as diesel fuel or kerosene. Never use gas or other highly volatile materials to start fires.
10. Store oxygen, acetylene and all LP gas cylinders outside in separate racks away from sources of heat or ignition. Keep upright with caps in place.
11. Follow safe practices in cutting and welding operations.
12. Fire protection shall be available when using space heaters. Never allow use of open fires or oil fire pots for heating enclosed spaces.
13. Class "ABC" fire extinguishers only to be used in client facilities and compressor stations.

FIRE Extinguishers:

ABC type fire extinguishers will be located throughout the work area, as well as on each piece of equipment. Please familiarize yourself as to the locations of these fire extinguishers.

Type, Care and Use of Extinguishers:

1. Always place extinguishers as close as possible to the hazard they are intended to control. Extinguishers are to be kept charged at all times and must be inspected by an outside source on an annual basis. In addition to the annual inspection, monthly in-house inspections must take place. Care should be taken to insure that all pins, tags and gauges are intact and in good repair.
2. All Sub-Contractors are responsible for fire extinguisher training of their personnel.
3. Sub-Contractors are responsible for fire prevention relative to and as hazards develop within their work areas.

COMPRESSED AIR / GAS CYLINDERS:

1. Oxygen and fuel/gas (acetylene, LPG, etc.) cylinders should be stored outside at least 20 feet apart or separated by a metal firewall.
2. Never use an oxygen or fuel/gas cylinder when it is lying down. Cylinders not in use should be fitted with their valve protection cap and secured in an upright position.
3. When cylinders are hoisted, always use proper carriers. They should never be choked or lifted by their valve protection cap.
4. Never use oily or greasy hands, gloves or rags to handle oxygen cylinders.
5. Empty cylinders should not be treated any differently than full cylinders.

LADDERS:

1. Inspect ladders before use. Defective ladders (broken or split side rails, missing rungs or steps, or other faulty/defective construction) shall be removed from service and disposed of off site.
2. Ladders should extend at least 36" above the landing.
3. Ladders shall be placed on a substantial base with clear access at both the top and bottom.
4. Place ladder at such a pitch that the horizontal distance from the top support to the base is about one quarter of the working length of the ladder.
5. When climbing the ladder, use both hands and face the ladder. A hand line shall be available at each ladder to hoist tools or material.
6. Job-made ladders shall be constructed for their intended use. Space cleats uniformly, 12" top to top.
7. When climbing ladders personnel should maintain three points of contact.
8. Ladders with metal side rails will not be used in the vicinity of electrical contacts.

REMEMBER- Secure your ladder to prevent unexpected movement!!!

ELECTRICAL

1. All 120 volt 15-20 amp receptacles used during the course of construction shall have ground fault circuit interrupters installed for personnel protection.
2. All electrical tools and equipment must be grounded or double insulated.
3. Sub-Contractors shall visually inspect their tools daily.

Any repair to electrical extension cords shall be performed by a competent source. All electrical tools and equipment must be grounded or double insulated. Temporary electrical cords must be covered or elevated in locations where they may be subject to damage.

Energized wiring in outlets, junction boxes, circuit breaker panels, etc., must be covered at all times. If you lose power, do not randomly trip circuit breakers at the panel. Call an electrician for help.

HAND AND PORTABLE POWER TOOLS:

Check hand and power tools regularly to ensure that they are in good condition. Defective or damaged tools must not be used. Always follow the manufacturers' recommendations relating to the proper use of the equipment. Saws, grinders and other power tools that require guards must have guards in place at all times. Removal or rendering these guards inoperative is strictly prohibited.

All fuel must be stored and transferred in an approved type safety can.

Flow control valves (check valve) must be installed at the manifold outlet of each supply line for hand-held air tools. All airline connections must be wired together, or properly secured by means of wire clips or other authorized ways.

Hand tools must be kept in good condition. Worn or broken tools such as hammers with loose handles, chisels with mushroomed heads, saws with teeth not set, shovels with splintered or split handles, etc., must be replaced.

HOISTING EQUIPMENT, SLINGS AND RIGGING:

It is very important with all hoisting equipment to comply with the manufacturer's specifications and limitation. Rated load capacities, recommended operating speeds, and special hazard warnings must be carefully adhered to. Frequent inspections and testing of this type of equipment is imperative. The following rules recommend the minimum precautionary measures.

- ◆ It should be the primary responsibility of the equipment operator to see that his equipment is not overloaded.
- ◆ Inspect all hoisting equipment before using.
- ◆ Never exceed the rated capacity of blocks, slings, cables, ropes, or other hoisting equipment. Keep wire rope, moving parts, etc. lubricated with light motor oil.
- ◆ Stand clear of all lines under strain.
- ◆ Never stand in the bight of a line (when the line makes a turn over itself). Apply power to load lines slowly. Never jerk load lines.
- ◆ Assign only one person at a time to give signals to operators of hoisting equipment. A relay man may be needed. Learn and use proper hand signals.
- ◆ Use only a trolley designed for the size of the trolley beam where it is to be hung. Attach wire rope clips with the "U" bolt on the "dead end" of the rope.
- ◆ Never use a chain or cable on loads with smooth surfaces because slippage may occur.
- ◆ A load should never be lifted and left unattended.
- ◆ Personnel should not work or stand under loads being lifted or between loads and fixed points.
- ◆ Inspect slings and tag lines daily.
- ◆ A documented inspection will be completed quarterly.
- ◆ Wire rope shall be lubricated to protect against wear and corrosion. The date slings are placed in service shall be affixed to the slings.
- ◆ Use slings of proper diameter and strength. NOTE: Never use two slings in parallel to get double strength.
- ◆ Do not position your hands so that they can be caught between the load and adjacent objects when guiding a load.
- ◆ Attach tag lines to loads; never attach tag lines to slings.
- ◆ Taglines must be long enough to allow you to safely direct the load without putting yourself under the load or be struck when, and if, the load spreads or shifts during landing.
- ◆ Use a bar to guide the cable or line onto a drum of a hoist. Never use hands or feet. Seat chain links into a hook by hand pressure. Never hammer them.

- ◆ Never connect or repair chains by bolting lengths together.
- ◆ Chains shall be used with appropriate hitch methods (single leg or basket hitch)

EQUIPMENT LIFTING:

It is important that the operator of any equipment insures that their equipment meets the recommended specifications of the manufacturer and applicable safety standards. The operator is also responsible for proper operating procedures to insure safety to himself and anyone in proximity of that equipment and the load. The following rules recommend some of the minimum precautionary measures. If any of the following rules, conditions, or good practices cannot be followed, the appropriate parties must be notified as soon as possible.

- ◆ Equipment shall be properly operated and maintained in accordance with manufacturer's guidelines and applicable regulations.
- ◆ Operators shall be qualified through training and experience. Where applicable, they shall be certified to meet the requirements of the appropriate agency.
- ◆ Boom, cables, rigging, control cables, and safety devices shall be visually examined and determined to be functioning properly by the operator each day before starting operations. The examination shall include, but not be limited to, a visual examination for cracked welds, cable defects, bent braces, sheave conditions, deformed or broken hooks, and any other defects.
- ◆ The operator shall not operate the equipment until persons involved have been instructed as to the work to be performed.
- ◆ Load limits for equipment shall be posted in clear view of the operator. The rated load capacity of the equipment shall not be exceeded.
- ◆ Employees shall be clear of a load before it is picked up or landed and must remain clear at all times.
- ◆ Employees shall not stand or pass under suspended loads.
- ◆ Taglines shall be used when it is necessary to control the load- NEVER ATTEMPT TO CONTROL A LOAD WITH YOUR HANDS.
- ◆ The operator shall properly secure the boom before going off duty or when shutting down operations.
- ◆ Maintenance inspections shall be made on side booms and their cables.
- ◆ During operation, at least three wraps of cable shall be maintained on the drum at all times.
- ◆ Hooks shall not be used without safety bolts or latches. Where a worker would have to put themselves in harms way by using a safety latch, the safety latch may be removed as long as all personnel are clear of any load and this is included in the JSA.

The following are examples of such instances:

- ◆ Handling timber mats.
- ◆ Handling steel plates.
- ◆ Rotating or moving parts on the equipment shall be guarded. Guards removed to make repairs, lubrication, or adjustments shall be replaced immediately after completion of the process.
- ◆ Good housekeeping shall be practiced in equipment areas.
- ◆ Equipment shall not be operated in adverse weather (lighting storm, high winds, etc.).

PHYSICAL HAZARDS:

A variety of physical hazards could be present during various phases of pipeline construction. They are, but are not limited to, the following:

Co-workers & Equipment

Employees will be in the presence of other employees and moving equipment. Any person coming within range of operating equipment should ensure the operator acknowledges their presence prior to traversing their work area. Employees must be aware that co-workers, not necessarily from their crew,

may enter their work space without prior notification and may not be aware of the hazards associated with your task. All precautions should be taken to ensure co-workers are aware of you and the work you're performing.

Utilities:

Overhead and underground utilities are typically marked and identified prior to construction, however, both marked and unmarked utilities present a potential hazard that all assigned personnel should be trained to avoid or properly react to.

Noise:

DEL may identify high noise areas and post appropriate warning signs so appropriate actions can be initiated. Employees should report suspected high noise areas to the Safety Department or immediate supervisor. Hearing protection shall be worn in high noise areas.

WEATHER:

Heat:

The work location may be hot in the late spring and summer. All assigned personnel should be trained to recognize signs of heat related illnesses such as heat exhaustion, heat stroke, dehydration and sunburn.

Heat Exhaustion Signs

1. Cool Skin
2. Moist Skin
3. Pale Skin
4. Red Skin
5. Heavy Sweating
6. Dilated Pupils
7. Headache
8. Nausea
9. Dizziness
10. Weakness
11. Exhaustion

Heat Stroke Signs

1. Dry Hot red Skin
2. Very High Temp.
3. Loss of Consciousness
4. Fast Weak Pulse
5. Fast Shallow Breathing

First Aid

1. Place Person in Cool Place
2. Place Person on their Back
3. Elevate Feet

First Aid

1. Life Threatening Call EMT
2. Place Person in Cool Place
3. Cool Victim Quickly without going into shock
4. Loosen clothing
5. Cool by fanning
6. Cool by ice packs
7. Care for shock
8. Glass of water every 15 minutes if conscious

Warning: Heat Exhaustion Can Become Heat Stroke Quickly
Warning: Heat Stroke is Life Threatening.

The work location may be cold in the late fall and winter. All assigned personnel should be trained to recognize signs of cold related illnesses such as hypothermia and frost bite.

When a person's body temperature drops even a few degrees below normal, the loss of body heat is known as "cold stress" or hypothermia. Persons who work outdoors, or who enjoy outdoor activities should learn about how to protect against loss of body heat.

Some symptoms of hypothermia include:

- Pain in the extremities
- Shivering and cold skin sensation
- Rigid Muscles
- Reduction of Body Core Temperature
- Irritability of heart muscle, sometimes heart beating abnormally
- Slow irregular breathing
- Drowsiness and Incoherence
- Diminished reaction time, coordination, judgment, and dexterity

The following guidelines can help you keep your body warm and avoid the dangerous consequences of hypothermia:

- DRESS IN LAYERS - Outdoors, indoor in mild weather or in cold, it pays to dress in layers. Layering your clothes allow you to adjust what you're wearing to suit the temperature conditions. Wool, polypropylene or under armor material wick moisture away.
- KEEP DRY - Water chills your body far more rapidly than air or wind. Always take along a dry set of clothing whenever you are working outdoors. Wear waterproof boots in damp or snowy weather.
- TAKE A COMPANION - The effects of hypothermia can be gradual, and often go unnoticed until it's too late. If you know you'll be outdoors for an extended period of time, take along a companion. (At the very least, let someone know where you'll be and at what time you expect to return.)

NOTE: THE KEY INGREDIENTS TO PREVENTING LOSS OF BODY HEAT ARE STAYING WARM AND UNDERSTANDING WHAT YOU CAN DO TO PROTECT AGAINST CONDITIONS THAT CAN CAUSE HYPOTHERMIA. HYPOTHERMIA CAN BE FATAL, BUT IT CAN ALSO BE PREVENTED.

Cold Weather Tips:

- ◆ Wear clothing to divert the wind.
- ◆ Stay hydrated, not with liquids that contain caffeine i.e.: coffee or soft drinks.
- ◆ Warm up as needed.
- ◆ Exposed skin will be more susceptible to frostbite
- ◆ Watch one another
- ◆ Know your own body limits Vehicles & Equipment.
- ◆ Don't trust the fuel gauges top off vehicles before you leave the area.
- ◆ If you become stranded in a vehicle don't eat the snow melt it and drink the water.
- ◆ Keep the exhaust area cleared out so you can warm yourself up in the vehicle.

- ◆ Keep a window on the downwind side cracked when running the vehicle.
- ◆ Stay with the vehicle, don't try to walk out even if you can see a light in the distance.
- ◆ Keep a winter survival kit in vehicle i.e.: blanket, flashlight
- ◆ Carbon monoxide is heavier than air and will accumulate in low lying areas. Park idling vehicles away from open excavations.
- ◆ Machinery will operate differently in cold and extreme cold conditions. Slow down and be aware of what it is telling you.
- ◆ Operators need to be aware of intentions when working around machinery. Never stand on the down slope side of equipment.
- ◆ Pay special attention to hydraulic equipment in extreme cold weather conditions. Booms and track hoes will bleed off quicker and chances of frozen or blown lines is greater.

	Calm	5 mph	10	15	20	25	30	35	40	45	50	55	60
T e m p e r a t u r e F °	40	36	34	32	30	29	28	28	27	26	26	25	25
	35	31	27	25	24	23	22	21	20	19	19	18	17
	30	25	21	19	17	16	15	14	13	12	12	11	10
	25	19	15	13	11	9	8	7	6	5	4	4	3
	20	13	9	6	4	3	1	0	-1	-2	-3	-3	-4
	15	7	3	0	-2	-4	-5	-7	-8	-9	-10	-11	-11
	10	1	-4	-7	-9	-11	-12	-14	-15	-16	-17	-18	-19
	5	-5	-10	-13	-15	-17	-19	-21	-22	-23	-24	-25	-26
	0	-11	-16	-19	-22	-24	-26	-27	-29	-30	-31	-32	-33
	-5	-16	-22	-26	-29	-31	-33	-34	-36	-37	-38	-39	-40
	-10	-22	-28	-32	-35	-37	-39	-41	-43	-44	-45	-46	-48
	-15	-29	-36	-39	-42	-44	-46	-48	-50	-51	-52	-54	-55
	-20	-34	-41	-45	-48	-51	-53	-55	-57	-58	-60	-61	-62
	-25	-40	-47	-51	-55	-58	-60	-62	-64	-65	-67	-68	-69
	-30	-46	-53	-58	-61	-64	-67	-69	-71	-72	-74	-75	-76
	-35	-52	-59	-64	-68	-71	-73	-76	-78	-79	-81	-82	-84
	-40	-57	-66	-71	-74	-78	-80	-82	-84	-86	-88	-89	-91
-45	-63	-72	-77	-81	-84	-87	-89	-91	-93	-95	-97	-98	

Where, T =Air Temperature (°F) V =Wind Speed (mph)Extreme Weather and Natural Disasters

When extreme weather is possible, the weather will be monitored and alerts given when there is a potential for extreme weather . Natural disasters can occur as a result of extreme weather. Conditions will be monitored and alerts will be given when there is a potential for a natural disaster (i.e. flooding) . In the event that extreme weather or natural disasters fall upon the work areas, the personnel in those areas should safely cease work and move to the nearest "safe" area. The safe area will be designated by the foreman and communicated to the crew members at the daily

Biological

All field activities should be taken with constant attention and awareness being given to the possibility of contact with or presence of:

- ◆ Poisonous Snakes.
- ◆ Wasps or Bees.
- ◆ Mosquitoes.
- ◆ Spiders.
- ◆ Poisonous Plants

All Sub-Contractors shall warn their employees of these potential hazards and prepare for any and all emergencies.

VEHICLE SAFETY REQUIREMENTS:

- ◆ Each employee that operates a company vehicle must possess a valid drivers' license issued by the state of his/her residence.
- ◆ All occupants must wear safety belts at all times while the vehicle is in motion.
- ◆ Drivers with cell phones must not place or accept phone calls while driving unless using a hands free system.

For drivers, texting while driving is never allowed.

- ◆ Employees operating company vehicles must obey all applicable motor vehicle regulations at all times.
- ◆ When parking on an inclined grade, set the parking brake and turn the wheels in a manner that will direct the vehicle toward the curb or bank should the transmission or parking brake fail.
- ◆ When parking vehicles on public roadways, vehicles must be pulled off to the side as far as possible.
- ◆ All vehicles must be facing the same direction and along only one side of the road so as to allow clear passage for the public.
- ◆ All DEL vehicles shall be equipped with a first aid kit and fire extinguisher.
- ◆ Vehicles equipped with "drag-up" fuel tanks shall carry spill diapers at all times.
- ◆ All vehicles must be backed in to parking spaces.
- ◆ Prior to backing any vehicle, a 360 degree walk around should be conducted prior to the vehicle being moved.
- ◆ Prior to backing any vehicle without a backup alarm, a honk of the horn shall be sounded to alert nearby personnel of the intention to back up.
- ◆ Any vehicle that has more than just an operator must have one of the occupants get out and ground guide that vehicle while it is backing up to its intended destination.
- ◆ Running lights or headlights must be on at all times while the vehicle is in motion.
- ◆ Unattended vehicles shall have the keys removed and the doors locked.
- ◆ All incidents/accidents must be reported immediately to the job Foreman and Safety office.
- ◆ Only DEL approved accessories are allowed on company vehicles.
- ◆ Anytime a passenger is in a vehicle, they must have appropriate seating with a restraint system.
- ◆ Personnel are not allowed to ride in the back of rigs or pickups.

RIGHT OF WAY RULES:

- ◆ Speed limit on the Right of Way is not to exceed 15 miles per hour.
- ◆ When driving on the right of way, always give the right of way to equipment and big trucks. Move out of their way as much as possible within the respective right of way limits.
- ◆ When operating a vehicle on the right of way, be sure use caution around the various types of terrain. Do not speed over hills and move your vehicle as far to the right when traversing blind areas.
- ◆ Workers are not to drive personal vehicles to the job site unless authorized by their supervisor. In the event that a personal vehicle is authorized on the job site, the right of way is given to DEL company vehicles.
- ◆ Only vehicles/equipment that are actively engaged in the task or process at a given location, are permitted to be parked (and left unattended) or located within 100 yards (300 feet) of the nearest piece of working equipment (otherwise defined as the "Construction Zone"). All other vehicles (including inspector's and visitor's vehicles) shall be parked outside the "construction zone" or off the R.O.W. in an area that does not impede traffic both on and off the Right of Way or, create a hazard to project personnel or members of the public.

SECTION V: STANDARD OPERATING PROCEDURES AND SITE SPECIFIC RULES

ZERO DISCHARGE AND WASTE MANAGEMENT POLICY

DEL employees and Sub-Contractors shall adhere to a "zero discharge" policy while working at any locations. In order to address the special threat that plastics present to the marine environment, employees and Sub-Contractors shall place any and all marine trash and debris such as plastic cups, paper, cigarette butts and packaging in the appropriate waste container. Hazardous wastes shall be disposed of ashore in strict compliance with U.S. EPA regulations. Procedures for each type of waste must be followed to assure proper packaging, handling and shipping.

In general terms, hazardous wastes are materials that exhibit qualities that are potentially harmful to humans and/or the environment and that are the remainder or by-products of production operations. They include materials and mixtures of materials that are toxic, corrosive, flammable, explosive, and carcinogenic.

DEL BASIC HS&E RULES

Safety Rules have been developed with input from supervision and employees. While held to a minimum, the rules address behaviors and work practices that can lead to accidents and injuries. Each employee, subcontractor, visitor, customer, and vendor shall become familiar with and follow the Safety Rules. Most accidents can be prevented if everyone uses assigned safety equipment and follows the established safety rules. To operate a safe and successful business, DEL must work as a team to think safe, work safe, and be safe. These following rules are fundamental and apply to all employees, subcontractors, visitors, customers, and vendors:

- ◆ Comply with all specific safety instructions such as posted signs, those given by your supervisor, and those listed in the Safety Handbook, where applicable.
- ◆ All injuries, no matter how slight, as well as every "near miss" or "close call" having potential to cause harm are to be reported to your supervisor immediately.
- ◆ Report any potential physical hazards and/or unsafe acts immediately to your supervisor.
- ◆ Consent to search of your person and baggage.
- ◆ Have no controlled substance such as drugs or alcohol on the job.
- ◆ Use of legal prescription drugs may be allowed, but must be reported to the site EMT prior to work.
- ◆ To have no firearms or weapons in your possession.
- ◆ Conduct or attend documented safety meetings and turn in DEL Safety Meeting Minutes.
- ◆ Horseplay and practical jokes are prohibited, as they may cause injury.
- ◆ Operate equipment, machinery, or power tools only when authorized to do so.
- ◆ To do all that you possibly can do to keep your work area free from hazards.
- ◆ Use only proper tools and equipment for the job and use them correctly as instructed by your supervisor.
- ◆ Should you need to use tools and equipment you are not familiar with, contact your supervisor before using.
- ◆ Overhead cranes are designed to lift straight up and should not be attached to loads on an angle.
- ◆ Before you start work, you must notify your supervisor of any permanent or temporary impairment that may reduce your ability to work in a safe manner.

- ◆ If there is any doubt as to the safe work method to be used, consult with your supervisor and agree on a safe work practice.
- ◆ Verify safety permits such as special entry, hot work, confined space, and lockout/tag out before start of work. It is your responsibility to inquire if a special permit is required or issued.

The DEL Basic Safety Rules cannot encompass all the safety procedures for every situation or condition, but does provide general information and guidelines that, when followed, should reduce accidents and control losses. When combined with good judgment, common sense, and knowledge of the work to be done, the principles of accident prevention become an integral part of the planning and efficient execution of every job.

DRUGS, ALCOHOL, FIREARMS AND PRESCRIPTION MEDICATIONS

DEL's policy on illegal drugs, alcohol, firearms and prescription medications is set forth below. DEL shall communicate this policy to all personnel that enter DEL property and all personnel shall agree to cooperate with DEL in implementing such policy on DEL property. Should an employee be taking prescribed or over-the-counter medications or drugs, he shall inform his supervisor of the fact and of the potential side effects (such as drowsiness, dizziness, euphoria, etc.) The Field Supervisor shall consider the employee's condition and the potential effects of the medication or drugs in assigning work duties so that safety is not compromised. The Field Supervisor shall notify the EMT of any personnel on prescription medication immediately, as well as of any situation that may cause a safety concern.

The use, possession, transportation, promotion, or sale of illegal drugs or drug paraphernalia, and/or otherwise legal but illicitly used substances, by anyone while on DEL premises is absolutely prohibited. Except where specifically authorized, the use, possession, or transportation of alcoholic beverages, firearms, or weapons is also prohibited. Any personnel on DEL property who are found in violation of these prohibitions will not be allowed on DEL premises and may be referred to law enforcement agencies for their actions. The term "DEL Premises" is used in the broadest sense and includes all land, property, buildings, structures, installations, boats, cars, trucks, and all other means of conveyance owned by or leases to DEL or otherwise being utilized in DEL business.

Entry onto DEL premises constitutes consent to and recognition of the right of DEL and its authorized representatives to search the person, vehicle, and other property of individuals while on DEL premises. Such searches may be initiated by DEL without prior announcement and will be conducted at such times and locations as deemed appropriate. Personnel who refuse to cooperate with a search will not be allowed on DEL premises. DEL may conduct contraband searches and drug testing of personnel on DEL premises in areas where personnel are performing work.

LOCKOUT/TAGOUT

The purpose of lockout/tag out is to isolate potentially hazardous energy or substances while employees are servicing and/or maintaining machines and equipment where an unexpected start up of machines/equipment or release of energy or substances could cause injury. When Lockout/Tag out (Energy Isolation) procedures are utilized, the affected personnel must be notified and appropriate supervisor should be notified. The only person authorized to remove a lock or tag is the person who put it in place (Authorized Personnel).

Extended Energy Isolation Work

Prior to commencing work on machinery or equipment that has been locked out for an extended period of time; the person performing the work is responsible for verifying that:

- ◆ Appropriate locks and tags are still in place; and
- ◆ The tag is still appropriate.

Changing Shifts

The integrity of the lockout/tag out system must be maintained during shift changes. Follow the guidelines below when changing shifts:

- ◆ Personnel coming on a shift to work on locked out equipment must actively participate in the lockout/tag out procedures.
- ◆ If the person who begins lockout/tag out procedures will not be the person completing the procedures, the incoming worker taking over responsibility must install his or her own lock(s) and tag(s) on the equipment prior to, or concurrent with, the removal of the original person's lock(s) and tag(s).
- ◆ For more information, refer to the topic "Removing Locks" in this section.

Lockout/Tag out -Tag Requirement

The DEL Lockout/Tag out Tag must be completed any time work is performed that requires isolation of potential energy sources. This tag may be supplemented by additional tags or lists, and Site-specific procedures as long as the basic tag and its requirements are not replaced or eliminated.

Periodic Inspection

A periodic inspection is done, looking at the energy control procedures performed to ensure that the procedure and requirements of the standard are being followed. This inspection is performed by a supervisor other than those actually using the lockout/tag out in progress. The inspection should be documented in the supervisor's log book and include date, equipment, and employees involved.

HYDROGEN SULFIDE (H₂S)

Characteristics

Hydrogen sulfide (H₂S) is a highly toxic, colorless gas, 1.2 times heavier than air, soluble in water, with the odor of rotten eggs in low concentrations. It is produced in toxic concentrations along with crude oil, water, and gas in certain producing fields. Activities in suspected areas that may lead to exposure include, but are not limited to, gauging tanks, repairing leaks, working in confined spaces, or cleaning and repairing tanks. H₂S is flammable and produces toxic sulfur dioxide when burned.

H₂S may also be present around sulfur mining operations at wells, ditches, and settling ponds.

General

Where H₂S is encountered or suspected initially in a field, measurements shall be made to determine concentrations and potential exposure levels. In addition, the safety representative shall be notified so appropriate protective measures can be implemented.

Some facilities (for example, certain tank batteries, wells, heat exchangers, etc.) and work areas require the use of respiratory protection equipment. Employees who may be exposed to H₂S shall wear respiratory protection equipment as required, including, but not limited to, when gauging tanks and repairing line leaks. Suitable respiratory protection includes SCBA's and full-face airline respirators with 5-minute egress bottles.

Toxicity

H₂S is an extremely toxic and irritating gas. The principal potential hazard is asphyxiation by inhalation of the gas. H₂S reduces the oxygen-carrying capacity of the bloodstream, depressing the nervous system. Sufficiently high concentrations can result in immediate collapse and death from respiratory failure and asphyxiation.

There is no evidence that repeated exposure to H₂S results in cumulative or systemic poisoning, or that repeated exposure increases or decreases a person's susceptibility to this gas.

Exposure to concentrations of H₂S greater than 600 parts per million (ppm) can cause immediate death. The "rotten egg" odor of H₂S is not a reliable warning sign because higher concentrations (approximately 100 ppm and greater) temporarily deaden the sense of smell. An exposed person may not detect the presence of H₂S and, consequently, inhale lethal amounts. The only positive means of determining the amount of H₂S present is by testing with an approved H₂S detector. **Relying solely on the sense of smell can be fatal.** However, if H₂S is detected by smell, immediately evacuate upwind.

Detection

Various types of monitoring equipment are available to determine the presence of H₂S. These include hand pumps with detector tubes, direct reading portable monitors, fixed monitor/alarm systems, and personal monitor/alarm systems.

Monitoring equipment shall be calibrated and tested. The safety or IH representative shall be consulted on the use, maintenance, and calibration/test schedule of each specific unit.

Training:

Employees shall not work in an H₂S area without first receiving training on potential hazards associated with H₂S, in the use of respiratory protection, emergency response, and first aid.

This training shall be done at least annually or as each individual job requires.

EXCAVATION SAFETY

- ◆ A person knowledgeable of the various applicable government rules will perform a pre-job survey to assure all underground utility locations are clearly marked and inspect the excavated work area at the start of each shift.
- ◆ Trenching and excavation support systems will be designated by a competent person to assure the slope or brace will resist the extra pressure due to superimposed loads created by heavy equipment working near the excavation.
- ◆ Each trench/excavation must be inspected and documented daily by the responsible.
- ◆ Competent person. If there is evidence of cave-ins or slides, all work on the excavation/trench must cease until necessary precautions have been taken to safeguard employees.
- ◆ Sides of excavations/trenches must be shored or braced as necessary to withstand superimposed forces exerted by vehicles/equipment operating near any excavation/trench.
- ◆ Trenches five (5) feet or deeper must be shored or sloped back to the angle of repose.
- ◆ Trenches and excavations of lesser depth in unstable soil may require shoring or sloping.
- ◆ No spoil piles, material, equipment or tools may be placed within two (2) feet of the edge of an excavation. Adequate precautions must be taken to prevent such tools, equipment and/or material from falling into the excavation.
- ◆ Safe access into and out of all excavations/trenches via ladders, stairs or ramps must be provided.
- ◆ Trenches four (4) feet or deeper must have ladders spaced so that employee lateral travel does not exceed 25 feet. Such ladders must extend at least three (3) feet above grade level.
- ◆ When there is any possibility of oxygen deficiency or concentration of hazardous or explosive gases or dusts, the atmosphere in the excavation/trench must be tested prior to start of work and at periodic intervals as required for entry into a confined space.
- ◆ Excavations shall be inspected prior to entry and after every rainfall or other hazard- increasing occurrence.
- ◆ Excavations and trenches near vehicular or pedestrian travel ways must be flagged and barricaded with snow fence or by other means. A warning light may be added where necessary.

CONFINED SPACE ENTRY

General Requirements

These requirements are intended to protect workers from toxic, explosive, or asphyxiating atmospheres and from possible engulfment from liquids or finely divided (flow able) solid substances. It focuses on areas with potential health or safety risks, denoting these as permit-required confined spaces. When dealing with confined spaces, observe the following safety guidelines:

- ◆ Evaluate the workplace to determine if any spaces are permit-required confined spaces.
- ◆ Inform all employees, subcontractors, vendors, and visitors of confined spaces through training and by posting danger signs, when appropriate, at each confined space. Danger signs should read:

DANGER - PERMIT REQUIRED - CONFINED SPACE: DO NOT ENTER

- ◆ Continue surveillance for unidentified confined spaces. Make requirements in this chapter and job site-specific confined space entry guidelines and programs available for review by employees and their authorized representatives.
- ◆ Before removing an entrance cover, eliminate any condition making it unsafe to remove the cover. After removing entrance covers, promptly guard the opening with a railing, temporary cover, or other temporary barrier that can prevent an accidental fall through the opening and protect each employee working in the space from foreign objects entering the space.
- ◆ Take effective measures to ensure that unauthorized individuals do not enter confined spaces.
- ◆ Identify and evaluate the hazards of confined spaces before allowing employees to enter them.
- ◆ Develop and implement means, guidelines, and practices necessary for safe confined space entry operations, including, but not limited to, the following:
 - ◆ Specifying acceptable entry conditions.
 - ◆ Isolating the confined space.
 - ◆ Purging, inverting, flushing, or ventilating the confined space as necessary to eliminate or control atmospheric hazards.
 - ◆ Providing pedestrian, vehicle, or other barriers, as necessary, to protect entrants from external hazards.
 - ◆ Verifying that conditions in the confined space are acceptable for entry throughout the duration of an authorized entry

Protection and Rescue Equipment

The following equipment must be provided at no cost to employees, properly maintained, and used as required:

- ◆ Testing and monitoring equipment needed to identify and evaluate atmospheric hazards.
- ◆ Ventilating equipment needed to obtain acceptable entry conditions.
- ◆ Communication equipment necessary to provide communications between the attendant and entrants and for summoning rescue and emergency services.
- ◆ PPE when feasible engineering and work practice controls do not adequately protect employees.
- ◆ Lighting equipment needed to enable employees to see well enough to work safely and exit the space quickly in an emergency.

- ◆ Barriers and shields to protect entrants from external hazards.
- ◆ Equipment and services, such as ladders, needed for safe ingress and egress by authorized entrants.
- ◆ Rescue and emergency equipment needed to rescue entrants from confined spaces.
- ◆ Any other equipment necessary for safe entry into and rescue from confined spaces.

Testing Atmospheric Conditions

Evaluate confined space conditions as follows when entry operations are conducted:

- ◆ Test conditions in the confined space to determine whether acceptable entry conditions exist before entry is authorized to begin.
- ◆ If isolation of the space is unfeasible because the space is large or is part of a continuous system such as a sewer, perform pre-entry testing to the extent feasible before entry is authorized and, if entry is authorized, continuously monitor entry conditions in the areas where authorized entrants are working.
- ◆ Test or monitor the confined space as necessary to determine whether acceptable entry conditions are being maintained during the course of entry operations.
- ◆ When testing for atmospheric hazards, test first for oxygen, then for combustible gases and vapors, and then for toxic gases and vapors.

Confined Space Entry Permit System

Before authorized entry into a confined space, DEL must prepare an entry permit to document the completion of measures required by the guidelines in this chapter. The Confined Space Entry Permit is an example of a confined space entry permit whose elements are considered to comply with the requirements of these guidelines.

Before entry begins, the entry supervisor, identified on the confined space entry permit, must sign the permit to authorize entry. The duration of the confined space entry permit may not exceed the time required to complete the assigned task or job identified on the permit. Make the completed confined space entry permit available to all authorized entrants at the time of entry by posting it at the entry portal.

The entry supervisor must terminate entry and cancel the confined space entry permit when:

- ◆ The entry operations covered by the permit have been completed.
- ◆ A condition that is not allowed under the permit arises in or near the confined space.

DEL retains each canceled permit-required confined space entry permit for at least one year to facilitate the review of the confined space program required by these guidelines. Note any problems encountered during an entry operation on the pertinent permit so that appropriate revisions to the confined space program can be made.

Confined Space Entry Permit

The confined space entry permit that documents compliance with this section and authorizes entry to the confined space must identify:

- ◆ The permit space to be entered.
- ◆ The purpose of the entry.
- ◆ The date and authorized duration of the confined space entry permit.
- ◆ The name of all authorized entrants within the confined space.
- ◆ The names of personnel serving as attendants.
- ◆ The name of the individual currently serving as entry supervisor, with a space for the signature or initials of the entry supervisor who originally authorized the confined space entry.
- ◆ The known hazards of the confined space to be entered.
- ◆ The measures used to isolate the confined space and eliminate or control confined space hazards before entry (those measures can include the lockout or tagging of equipment and guidelines for purging, inverting, ventilating, and flushing permit spaces). The acceptable entry conditions.
- ◆ The results of initial and periodic tests performed; accompanied by the names or initials of the tester and the dates the tests were performed.

- ◆ The rescue and emergency services that can be summoned and the means (the equipment to use and the numbers to call) for summoning those services.
- ◆ The communication guidelines used by authorized entrants and attendants to maintain contact during entry.
- ◆ Equipment such as PPE, testing equipment, communication equipment, alarm systems, and rescue equipment needed to comply with guidelines in this chapter.
- ◆ Any other information necessary, given the circumstances of the particular confined space, to ensure employee safety.
- ◆ Any additional permits, such as for hot work or excavation, that have been issued to authorize work in the confined space.

Personal Protective Equipment

PPE must be worn during confined space entry or operations. The rules for PPE are established by Management for the protection of the employees involved and are subject to change at the discretion of Management. Guidelines for using PPE are as follows:

- ◆ Eye protection: Safety glasses with side shields are required at all times. Where there is a danger of corrosive chemical splash or corrosive vapors in the area, chemical splash goggles must be worn. In some cases, face shields might be necessary in addition to goggles.
- ◆ Hard hats: Hard hats must be worn when there is danger of objects falling from above or of a chemical splashing, such as during solvent cleaning.
- ◆ Clothing: Minimize the amount of exposed skin. Provide special protection, such as rubber suits, special gloves, and even hoods, when warranted.
- ◆ Respirators: Respirators are not a substitute for adequate ventilation. Instances exist, however, during which they should be worn (for example, during solvent cleaning) or carried for emergencies. In such cases, select proper respirators and instruct employees in the use and maintenance of the respirators. In some cases, a self-contained breathing apparatus or fresh air-supplied mask might be required. Because of the difficulty of entering and leaving the vessel while wearing such equipment, harnesses and extra precaution might be necessary. Foot protection—Generally, rubber boots with a steel safety caps are desirable for work in vessels. Proper traction must be provided by the soles of whatever shoes are worn.
- ◆ Burn protection, when welding, is performed in a confined space, the possibility of burns to the body is much more prevalent than when welding is done in an open area.
- ◆ Proper protection against burns must be provided, and, in some cases, flame-resistant clothing might be required.

Confined Space Entry Training

Training is provided so that all employees whose work is regulated by these requirements acquire the understanding, knowledge, and skills necessary for the safe performance of the duties assigned while working within a confined space. Employees' are trained when.

- ◆ The employee is assigned duties requiring him or her to work within a confined space.
- ◆ There is a change in assigned duties of employees required to work within a confined space.
- ◆ There is a change in confined space operations that presents a hazard about which an employee has not previously been trained.
- ◆ The employer has reason to believe that deviations from the confined space entry guidelines or inadequacies in the employee's knowledge or use of these guidelines exist.
- ◆ Training establishes employee proficiency in performing work within confined spaces and may be revised, as necessary, for compliance with program requirements.
- ◆ The Company certifies that the training has been accomplished, and certification contains each employee's name, the signature or initials of the trainer, and the dates of training. The certification

must be available for inspection by employees and their authorized representatives.

Personnel Duties during Permit Space Operations

Entrants:

The duties of authorized entrants include:

- ◆ Knowing the hazards that might be faced during entry, including information on the mode, signs or symptoms, and consequences of the exposure.
- ◆ Properly using equipment as required.
- ◆ Communicating with the attendant, as necessary, to enable the attendant to monitor entrant status and alert entrants to evacuate the confined space as required.

Alerting the attendant whenever the entrant:

- ◆ Recognizes any warning sign or symptom of exposure to a dangerous situation
- ◆ Detects a prohibited condition.

Exiting from the permit space as quickly as possible whenever:

- ◆ An order to evacuate is given by the attendant or the entry supervisor.
- ◆ The entrant recognizes any warning sign or symptom of exposure to a dangerous situation.
- ◆ The entrant detects a prohibited condition.
- ◆ An evacuation alarm is activated.

Attendants

The duties of permit space attendants include:

- ◆ Knowing the hazards that might be faced during entry, including information on the mode, signs or symptoms, and consequences of the exposure.
- ◆ Being aware of possible behavioral effects of hazard exposure in authorized entrants.
- ◆ Continuously maintaining an accurate count of authorized entrants in the confined space and ensuring that the means used to identify authorized entrants accurately identifies who is in the confined space.
- ◆ Remaining outside the permit space during entry operations until relieved by another attendant.
- ◆ Communicating with authorized entrants as necessary to monitor entrant status and alert entrants to evacuate the space.
- ◆ Monitoring activities inside and outside the space to determine whether entrants can remain in the space or evacuate the confined space immediately when the attendant:
 - Detects a prohibited condition
 - Detects the behavioral effects of hazard exposure in an authorized entrant
 - Detects a situation outside the space that could endanger the authorized entrants.
 - Cannot effectively and safely perform all of the duties required.
- ◆ Summoning rescue and other emergency services as soon as the attendant determines that authorized entrants might need assistance to escape from confined space hazards. Taking the following actions when unauthorized persons approach or enter a permit space while entry is underway:
 - Warn the unauthorized persons that they must stay away from the confined space.
 - Advise the unauthorized person that they must exit immediately if they have entered the confined space.
 - Inform the authorized entrants and the entry supervisor if unauthorized persons have entered the confined space.
- ◆ Performing non entry rescues as specified by the rescue guidelines.
- ◆ Performing no duties that might interfere with the attendant's primary duty to monitor and protect the authorized entrants.

Entry Supervisors

The duties of entry supervisors include:

- ◆ Knowing the hazards that might be faced during confined space entry, including information on the mode, signs or symptoms, and consequences of the exposure.
- ◆ Verifying, by checking that the appropriate entries have been made on the confined space entry permit, that all tests specified by the permit have been conducted and that all guidelines and equipment specified by the permit are in place before endorsing the permit and allowing entry to begin.
- ◆ Terminating the entry and canceling the permit as required.
- ◆ Verifying that rescue services are available and the means for summoning them are operable.
- ◆ Removing unauthorized individuals who enter or attempt to enter the permit space during entry operations.
- ◆ Determining, whenever responsibility for a permit space entry operation is transferred and at intervals dictated by the hazards and operations performed within the confined space, that entry operations remain consistent with terms of the Confined Space Entry Permit and acceptable entry conditions are maintained.

Rescue and Emergency Services

The following guidelines apply when employees enter confined spaces to perform rescue services:

- ◆ Ensure that each member of the rescue team is provided with, and is trained to properly use, the PPE and rescue equipment necessary for making rescues from confined spaces.
- ◆ Ensure that each member of the rescue team has been trained to perform assigned rescue duties. Each member of the rescue team must also receive the training required of authorized entrants.
- ◆ Ensure that each member of the rescue team has practiced making confined space rescues by means of simulated rescue operations in which they remove dummies, mannequins, or actual persons from the actual confined spaces or from representative confined spaces. Representative confined spaces must simulate the opening size, configuration, and accessibility of types of permit spaces from which rescue is to be performed.
- ◆ At least one member of the rescue team holding current certification in first aid and in CPR must be available.
- ◆ When DEL arranges to have outside persons or mutual aid perform confined space rescue:
 - Inform the rescue service of the hazards they might confront when called to perform a rescue at the facility.
 - Provide the rescue service with access to all confined spaces from which rescue might be necessary so that the rescue service can develop appropriate rescue plans and practice rescue operations.
- ◆ To facilitate non-entry rescue, use retrieval systems or methods whenever an authorized entrant enters a confined space, unless the retrieval equipment would increase the overall risk of entry or would not contribute to the rescue of the entrant. Retrieval systems must meet the following requirements:
 - Each authorized entrant must use a chest or full body harness, with a retrieval line attached at the center of the entrant's back near shoulder level or above the entrant's head. Wrist lets may be used in lieu of the chest or full body harness if it can be demonstrated that the use of a chest or full body harness is unfeasible or creates a greater hazard and that the use of wrist lets is the safest and most effective alternative.
 - The other end of the retrieval line must be attached to a mechanical device or fixed point outside the confined space in such a manner that rescue can begin as soon as the rescuer becomes aware that rescue is necessary. A mechanical device must be available to retrieve personnel from vertical-type permit spaces more than 5 ft. (1.52m) deep. If an injured entrant is exposed to a substance for which an MSDS or other similar written information is required to

be kept at the work site, provide the MSDS or written information to the medical facility treating the exposed entrant.

Guidelines for Atmospheric Testing

Atmospheric testing is required for two distinct purposes: evaluation of the hazards of the confined space and verification that acceptable entry conditions for entry into that space exist.

Evaluation Testing

The atmosphere of a confined space should be analyzed using equipment of sufficient sensitivity and specificity to identify and evaluate any hazardous atmospheres that may exist or arise, so that appropriate permit entry guidelines can be developed and acceptable entry conditions stipulated for that space. Evaluation and interpretation of this data and development of the entry guidelines should be done or reviewed by a technically qualified safety professional based on evaluation of all serious hazards.

Verification Testing

The atmosphere of a confined space that might contain a hazardous atmosphere should be tested for residues of all contaminants identified by evaluation testing using permit-specific equipment to determine that residual concentrations at the time of testing and entry are within the range of acceptable entry conditions. Results of testing (that is, actual concentration of contaminants, flammability levels, and so on) should be recorded on the permit in the space provided adjacent to the stipulated acceptable entry condition.

Duration of Testing

Measurement of values for each atmospheric parameter should be made for at least the minimum response time of the test instrument specified by the manufacturer.

Testing Stratified Atmospheres

When monitoring for entries involving a descent into atmospheres that might be stratified, the atmospheric envelope should be tested a distance of approximately 4 ft. (1.22 m) in the direction of travel and to each side. If a sampling probe is used, the entrant's rate of progress should be slowed to accommodate the sampling speed and detector response.

Atmospheric Monitoring

Entrants should be trained in the use of, and be equipped with, atmospheric monitoring equipment that sounds an audible alarm, in addition to its visual readout, whenever one of the following conditions is encountered:

- ◆ Oxygen concentration less than 19.5%
- ◆ Flammable gas or vapor at 10% or more of the LFL
- ◆ Hydrogen sulfide or carbon monoxide at or above their Permissible Exposure Limits (PEL) (10 ppm or 50 ppm, respectively)
- ◆ A broad range sensor device is used, at 100 ppm as characterized by its response to toluene

Normally, the oxygen sensor/broad range sensor instrument is best suited for sewer entry. However, substance-specific devices should be used whenever actual contaminants have been identified. The entrant should carry and use the instrument in sewer line work to monitor the atmosphere in the entrant's environment and, in advance of the entrant's direction of movement, to warn the entrant of any

deterioration in atmospheric conditions. Where several entrants are working together in the same immediate location, one instrument, used by the lead entrant, is acceptable.

OVERHEAD POWERLINES

Personnel performing work in the vicinity of overhead power lines or exposed energized conductors shall not approach nor permit equipment or objects to approach the power line or conductor closer than the safe limit of approach distance specified below:

Minimum Safe Limits of Approach	
Voltage (nominal, kV, AC)	Minimum Distance (Feet)
Up to 50	10
Over 50-200	15
Over 200-350	20
Over 350 to 500	25
Over 500 to 750	35
Over 750 to 1,000	45
Over 1,000	As established by the utility owner/operator or qualified registered professional engineer

When in transit with no load and boom lowered, the equipment clearance shall be a minimum of 4 feet for voltages less than 5 KV., and 10 feet for voltages over 50 KV., up to and including 34 KV., and 16 feet for voltages up to and including 750 KV.

In locations where live lines are particularly low and normal methods for crossing under the power line may not be feasible, one of the following options may be used:

- Utility Company deactivates the line
- Utility Company permanently or temporarily deactivates the line
- Utility Company installs insulators around the lines.

SIGNS TO FACE TRAFFIC OR USE (2) SIGNS BACK TO BACK

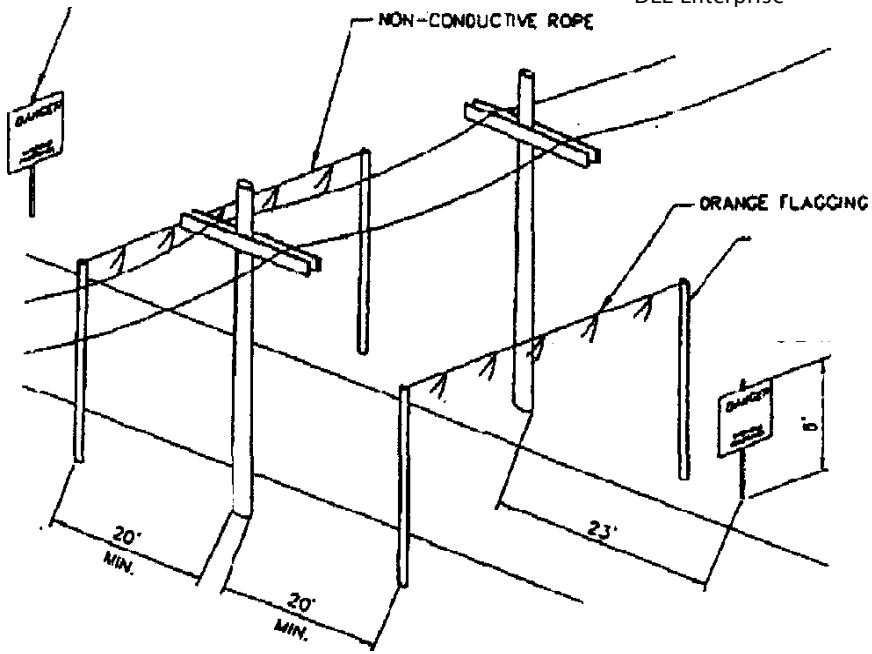

THE MINIMUM SAFE DISTANCE OF APPROACH

The Utility Foreman Shall:

- ◆ Contact the operator of the overhead power line or exposed electrical or exposed electrical conductor to determine the operating voltage of all the lines or conductors; some utility owners require a permit approval process.
- ◆ Erect temporary warning signs at approaches to overhead lines which include the height of the lowest live line.
- ◆ Examine the work area to determine that safe limits of approach distances can be maintained.
- ◆ If work activities are being carried out near the safe limits of approach distances, a safety watch (spotter) who is equipped with an air horn must be in position to ensure the minimum distances are being maintained. The spotter's only job at this time is to ensure that the equipment is within these safe limits of approach. The heights of power lines will be verified by non physical means to assure warning signs and devices are set at the correct height.
- ◆ All overhead lines shall be considered to be an energized line unless and until the person owning such line or the electrical utilities authorities confirm that it is not an energized line and it has been visibly grounded.

Power Line Protective Systems:

A guard consisting of a non-conductive pole on each side of the R.O.W. connected by a non-conductive rope shall be installed twenty (20) feet away from and on each side of the overhead power line. All underground facilities shall be located prior to the installation of the guard poles, in order to prevent damage to existing facilities. The height of the non-conductive rope shall be per-determined and in accordance with minimum safe limits of approach.

Overhead power lines shall be identified with signs placed approximately twenty feet on either side of the overhead power line, four to six feet above grade and in view of equipment traveling either direction under the power line.

Signs shall be installed before the work commences, and be maintained throughout construction activities. Orange traffic barrels are to be positioned on the right of way within the goal post area to add an extra visual for workers as they are approaching or crossing under power lines. In addition, each crew's respective foreman must sign off at each overhead power line crossing that all safe guards are in place prior to removing the protections at the crossing, and that they have been returned to place after crossing. These sign off forms are in mailboxes at each power line. A spotter who is equipped with an air horn, and the foreman will be in place for the whole duration that the protections are removed.

FALL PREVENTION AND PROTECTION GUIDELINES**General Requirements**

These guidelines establish the minimum fall prevention and protection requirements for all employees working at or over 6 feet above the ground or the next lower level. They contain requirements for fall protection from structures, ladders, scaffolds, and aerial lifts. Fall protection may be required at lower levels if employees are exposed to other hazards.

The intent of these guidelines is to prevent employees from falling off, onto, or through working levels and to provide protection from falling objects. The methods found in these guidelines are not the only methods by which protection can be achieved, and these guidelines and systems do not provide protection for every situation encountered in the workplace. Any questions about how to use these guidelines or proposals for alternative guidelines for a specific situation should be presented to the DEL HS&E Department.

The following guidelines for fall protection and prevention must be observed:

- ◆ DEL must determine whether walking or working surfaces can support workers safely. All required fall protection systems are to be provided and installed before beginning the work that requires the fall protection.
- ◆ Employees on walking or working surfaces with unprotected sides or edges 6ft (1.83 m) or more above a lower level must be prevented from falling by the use of safety net, personal fall arrest system, or positioning device system.
- ◆ These requirements apply to all elevated walking and working surfaces, including, but not limited to, leading edges, hoist areas, holes, the face of form work and reinforcing steel, ramps, runways and walkways, areas above or next to dangerous equipment, scaffolding, roofs, precast concrete structures, overhand bricklaying, and wall openings, where the hazard of falls is present.
- ◆ When it is infeasible or creates a greater hazard to install conventional fall protection systems to protect employees working on a leading edge or engaged in precast concrete erection or residential construction, a site-specific fall protection plan may be developed and carried out.

When fall protection is required on low slope roofs, conventional fall protection systems may be used alone or warning lines may be used in combination with any of the following protection Systems:

- ◆ Guardrails.
- ◆ Personal fall arrest system
- ◆ When employees are working below an elevated work area and toe boards do not provide sufficient protection from falling objects, screens, nets, mesh, or canopies must be installed for a distance sufficient to protect employees below.
- ◆ Where tools, equipment, or materials are piled higher than the top edge of a toe board, paneling or screening must be erected from the walking or working surface or toe board to the top of a guardrail system's top rail or mid rail for a distance sufficient to protect employees below.
- ◆ When canopies are used as falling object protection, they must be strong enough to prevent collapse and penetration by any objects that may fall onto the canopy.

Fall Protection Systems and Practices

Guardrail Systems

- ◆ When used for fall protection, guardrail systems must consist of top rails, mid rails, toe boards, and posts erected or constructed according to the following requirements:
 - Guardrail systems must be capable of withstanding, without failure, a force of at least 200 lb applied within 2 inches (5.08 cm) of the top edge, in any outward or downward direction at any point along the top edge.
 - The surface of the guardrail system must be maintained to prevent injury to an employee from punctures or lacerations and to prevent snagging of clothing.
 - The top edge height of top rails, or equivalent guardrail system members, must be 42 to 45 inches (106.68 to 114.30 cm) above the walking or working level.
 - The ends of all top rails and mid rails must not overhang the terminal post, except where they do not cause a projection hazard.
 - The mid rails must be installed at a height midway between the top edge of the guardrail system and the walking or working level.
 - Mid rails, screens, mesh, intermediate vertical members, solid panels, and equivalent structural members must be capable of withstanding, without failure, a force of at least 150 lb. (68.04 kg) applied in any downward or outward direction at any point along the mid rail or other member.
 - The toe boards must be at least 3-1/2 inches (3.89 cm) in height and must be installed within

1/4 inch (0.64 cm) of the walking or working surface.

- Toe boards must be capable of withstanding, without failure, a force of at least 50 lb. (22.68 kg) applied in any downward or outward direction at any point along the toe board.
- The posts must be spaced at intervals of 8 ft. (2.44 m) or less.
- ◆ Several combinations of materials that can be used to construct guardrail systems.
- ◆ When constructed according to the preceding height, strength, and spacing requirements, The following combinations are acceptable:
 - Wooden guardrails must be made of selected grade lumber that is free of damage.
 - The top rails and posts must be at least 2x4 inches (5.08x10.16 cm) (nominal), and the mid rails must be at least 1x6 inches (1.25x15.24 cm).
 - Pipe guardrails must be made of Schedule 40 pipe. The top rails, mid rails, and posts must have at least a 1-1/2 inch (3.81 cm) nominal diameter.
 - Structural steel guardrails must be made of angle iron. The top rails, mid rails, and posts must have at least 2x2-inch (5.08x5.08-cm) angles.
 - Wire rope may be substituted for top rails and mid rails but must be at least 1/4-inch (0.64-cm) nominal diameter or thicker. Wire rope used for top rails must be kept tight enough so that a 200-lb (90.72-kg) load will not deflect the line to less than 39 inches (99.06 cm) above the walking or working surface. Wire rope top rails must be flagged with high-visibility material at 6-ft (1.83-m) intervals.

Personal Fall Arrest and Positioning Device Systems

Rescue plans must be established before workers enter a walking or working environment for a prompt rescue of employees in case of a fall, unless it has been determined that employees can rescue themselves.

When used for fall protection, personal fall arrest and positioning device systems must be used according to the following requirements:

- ◆ Full body harnesses and all associated attachments must be labeled and must meet the requirements in ANSI Z 359.1. A body belt must not be used as part of a fall arrest System.
- ◆ Connectors must be drop forged, pressed or formed steel or made of materials of equivalent strength. They must have a corrosion-resistant finish, and their surfaces and edges must be smooth to prevent damage to other system components.
- ◆ D-rings and snap hooks must have a minimum tensile strength of 5,000 lb. (2,268.00 kg). They must have been proof tested by the manufacturer to a minimum tensile load of 3,600 lb. (1,632.96 kg) without cracking, breaking, or sustaining permanent deformation.
- ◆ Snap hooks must be of the locking type, sized to fit with the member to which they connect, and designed and used to prevent disengagement.
- ◆ Horizontal lifelines must be designed, installed, and used under the supervision of a qualified person as part of a complete personal fall arrest system that maintains a safety factor of at least 2:1. On work platforms where, because of an accident, a horizontal lifeline may become vertical, the device (such as a rope grab) used to connect to the lifeline can lock in both directions.
- ◆ Ropes and straps used in lanyards, lifelines, and components of body harnesses must be made from synthetic fibers. Lanyards and vertical lifelines must be protected against cuts or abrasions and have a minimum breaking strength of 5,000 lb. (2,268.00 kg). When using vertical lifelines, each employee must use a separate lifeline.
- ◆ Self-retracting lifelines and lanyards that automatically limit free fall distance to 2 ft. (0.61m) or less must be capable of sustaining a minimum tensile load of 3,000 lb. (1,360.80 kg) applied to the device with the lifeline or lanyard in the fully extended position.
- ◆ Self-retracting lifelines and lanyards that do not limit free fall distance to 2 ft. (0.61 m) or less rip stitch

lanyards, and tearing and deforming lanyards must be capable of sustaining a minimum tensile load of 5,000 lb. (2,268.00 kg), applied to the device with the lifeline or lanyard in the fully extended position.

- ◆ Anchorages used for attachment of personal fall arrest equipment must be independent of any anchorage being used to support or suspend platforms and capable of supporting at least 5,000 lb. (2,268.00 kg) per employee attached.
- ◆ Personal fall arrest systems must do all of the following when stopping a fall:
 - Limit maximum arresting force on an employee to 1,800 lb (816.67 kg).
 - Be rigged so that an employee cannot free-fall more than 6ft (1.83 m) or contact any lower level.
 - Bring an employee to a complete stop and limit maximum deceleration distance an employee travels to 3-1/2 ft. (1.07 m).
 - Have enough strength to withstand twice the potential impact energy of an employee free-falling 6 ft. (1.83 m) or the free fall distance allowed by the system, whichever is less.
- ◆ The attachment point of a full body harness used for fall protection must be in the center of the back near shoulder level or above the head.
- ◆ Harnesses and other fall arrest equipment may never be used for hoisting materials.
- ◆ Personal fall arrest systems and components subjected to impact loading must be immediately removed from service and not used until inspected and determined to be undamaged and suitable for service by a competent person.
- ◆ Personal fall arrest systems must be inspected before each use for wear, damage, or other deterioration. Defective components must be removed from service.
- ◆ Personal fall arrest systems must not be attached to guardrail systems.
- ◆ When personal fall arrest systems are used at hoist areas, they must be rigged to allow the movement of the employee only to the edge of the walking or working surface.
- ◆ Positioning devices must be rigged such that an employee cannot free-fall more than 2ft (0.61 m) and must be secured to an anchorage capable of supporting at least twice the potential impact load of an employee's fall or 3,000 lb (1,360.80 kg), whichever is greater.
- ◆ At a minimum, the fall protection plan must contain the following information:
 - Reasons why conventional fall protection systems are infeasible or would create a greater hazard.
 - A written discussion of other measures to be taken to reduce or eliminate the fall hazard (scaffolds, ladders, aerial lifts, and so on).
 - Locations where conventional fall protection measures cannot be used. These locations must then be classified as controlled access zones (CAZ).
 - The names or other methods of identifying each employee designated to work in a CAZ. Only those designated employees may enter a CAZ.
- ◆ A copy of the fall protection plan must be maintained at the job site whenever conventional fall protection systems are not being used. The fall protection plan must be implemented under the supervision of a competent person.

Controlled Access Zones

When CAZs are used to control access to areas where leading edge, precast concrete erection, overhand bricklaying, or related work is taking place, the CAZ must be defined by a control line or other means that restricts access.

- ◆ When used to control access to areas where leading edge and other operations are taking place, the control lines are to be erected no fewer than 6 ft (1.83 m) or more than 25ft (7.62 m) from the unprotected or leading edge, except when erecting precast concrete members.
- ◆ When erecting precast concrete members, the control line is to be erected no fewer than 6ft (1.83 m) or more than 60ft (18.29 m), or half the length of the member being erected, whichever is smaller,

from the leading edge.

- ◆ When used to control access on leading edge or precast concrete erection operations, the control line must:
 - Extend along the entire length of the unprotected or leading edge.
 - Be approximately parallel to the unprotected or leading edge.
 - Be connected on each side to a guardrail system or wall.
- ◆ When used to control access to areas where overhand bricklaying and related work are taking place, the control lines must be erected no fewer than 10ft (3.05 m) or more than 15 ft (4.57 m) from the working edge.
- ◆ When used to control access to areas where overhand bricklaying and related work are taking place, the control line must extend a far enough distance to enclose the employees and be approximately parallel to the working edge.
- ◆ Control lines must consist of ropes, wires, tapes, or equivalent materials with a minimum breaking strength of 200 lb. (90.72 kg) and be rigged and supported so that the line is between 39 and 45 inches (99.06 and 114.30 cm) above the walking or working surface.
- ◆ Control lines must be flagged or otherwise clearly marked with high-visibility material at intervals of not more than 6ft (1.83 m).

Holes and Covers

- ◆ Covers for holes in floors, roofs, and other walking or working surfaces must meet the following requirements:
 - Covers located in roadways and vehicular aisles must be capable of supporting, without failure, at least twice the maximum axle load of the largest vehicle expected to cross over the cover.
 - All other covers must be capable of supporting without failure, at least twice the weight of employees, equipment, and materials that may be set on the cover.
 - All covers must be secured when installed to prevent accidental displacement by wind, equipment, or employees.
 - All covers must be color-coded or marked with the word "HOLE" or "COVER" to provide warning of the hazard.

Ladders

- ◆ Ladders must be of proper size, design, and condition for their intended use and must not be used as work platforms. Ladders with bent, broken, or damaged rungs or side rails must be removed from service. Side rails of job-made ladders must be constructed of dressed, selected grade lumber or the equivalent and can only have knots less than 1/2 inch (1.27 m) in diameter that appear only on the wide face and are at least 1/2 inch (1.27 m) from either edge. If side rails must be spliced to attain the required length, the splice must provide the full strength of a continuous side rail of the same length.
- ◆ Side rails of single-cleat ladders up to 16 ft (4.88 m) long must be made of 2 x 4-inch (5.08 x 10.16-cm) lumber. Side rails of single-cleat ladders from 16 to 30ft (4.88 x 9.14 m) in length must be made of 3 x 6-inch (7.62- x 15.24-cm) lumber.
- ◆ Side rails and middle rails of double-cleat ladders up to 12ft (3.66 m) long must be made of 2 x 4-inch (5.08 x 10.16-cm) lumber. Side rails and middle rails of double-cleat ladders from 12 to 24ft (30.48 to 60.96 m) in length must be 2 x 6-inch.(5.08 x 15.24-cm) lumber.
- ◆ Cleats of job-made ladders must be clear, straight-grained, and free from knots of any size that appear in the narrow face. Knots appearing in the wide faces of cleats must not exceed a diameter of 1/4 inch (0.64 cm). Cleats must be uniformly spaced within 1/4 inch (0.64 cm) tolerance and not farther apart than 12 inches (3.66 m) measured from the tops of cleats.

- ◆ Cleats of job-made ladders must be inset into the edge of the side rails 1/2 inch (1.27 cm), or fill blocks must be used on the rails between the cleats. The cleats must be secured to each rail with three 10d common wire nails or other fasteners of equivalent strength. Single-cleat ladders must not exceed 30ft (9.14 m) in length between the base and top landing. If the length required exceeds these maximum lengths, two or more ladders must be used, offset with a landing or platform between each ladder. Guardrails and toe boards must be erected on the exposed sides of the platforms.
- ◆ If a job-made ladder provides the only means of access to a work area for 25 or more employees or if simultaneous two-way traffic is expected, a double-cleat ladder must be installed. Double-cleat ladders must not exceed 24ft (7.32 m) in length.
- ◆ Single-cleat ladders must have at least 15 inches (38.1 cm), but not more than 20 inches (50.80 cm), between rails.
- ◆ Double-cleat ladders must have at least 18 inches (45.72 cm), but not more than 22 inches (55.88 cm), between rails.
- ◆ Portable ladders must extend at least 36 inches (91.44 cm) above the top landing or be secured at the top and equipped with a grab rail. Fixed ladders must extend at least 42 inches (106.68 cm) above the top of access.
- ◆ All portable ladders must be placed on substantial footing and be tied, blocked, or otherwise secured to prevent displacement.
- ◆ Metal ladders must not be used if there is exposure to electrical or explosive hazards.
- ◆ Extension ladders must not exceed 44 ft. (13.41 m) in length when extended. When extended, the ladder sections must have the following minimum overlaps:
 - ◆ Two-section ladders-3ft (0.91 m) for working lengths of up to 33ft (10.06 m) and 4 ft (1.22 m) for working lengths of 33 to 44 ft. (10.06 to 13.41 m)
 - ◆ Three-section ladders-4ft (1.22 m) for each section
- ◆ Each employee using ladders must be trained, by a competent person, to recognize hazards related to ladders and must know the procedures to be followed to reduce these hazards. The training must include as applicable, the following information:
 - The nature of fall hazards in the work area
 - The correct procedures for erecting, maintaining, and disassembling the fall protection systems to be used
 - The proper construction, use, placement, and handling of ladders
 - The maximum intended load-carrying capacities of ladders
 - The federal and state regulations relating to this program
- ◆ If there is any reason to believe that an employee lacks the skill or understanding necessary for the safe operation on the job site, the employee must receive additional training in the areas listed in this section.

RESPIRATORY PROTECTION

General Requirements

These guidelines establish the minimum requirements for the use of respiratory protective equipment. The components of a respiratory protection program are:

- ◆ Selecting respirators
- ◆ Evaluating the medical condition of respirator users
- ◆ Fit testing
- ◆ Using respirators
- ◆ Maintaining respirators
- ◆ Ensuring adequate air quality, quantity, and flow for supplied-air respirators

When it is clearly impractical to remove respiratory hazards through engineering controls or where emergency protection against occasional or brief exposures is necessary, approved respiratory protective equipment is issued and used in accordance with this program.

These requirements apply to all exposures in which employees are required or allowed to wear respiratory protective equipment.

DEL will designate a program administrator to oversee the respiratory protection program and conduct the required evaluations of program effectiveness. The program administrator must be qualified by appropriate training or experience that is commensurate with the complexity of the program.

Respiratory hazards for the purpose of this program include the following classifications:

- Oxygen deficiency
- Gas and vapor contaminants
- Particulate contaminants
- Combinations of any of the hazards listed above

Procedures for Selecting Respirators:

- ◆ An evaluation is conducted to identify potential respiratory hazards in the workplace and relevant workplace and user factors. Respirator selection is based on these findings. This evaluation occurs during the estimation phase of all work.
- ◆ The evaluation of workplace hazards must include a reasonable estimate of employee exposures to respiratory hazards and an identification of the chemical state and physical form of the contaminant. Where employee exposure cannot be identified or reasonably estimated, the atmosphere must be considered to be IDLH.
- ◆ Only respirators certified by the National Institute for Occupational Safety and Health (NIOSH) for protection against a particular respiratory hazard are selected. All filters, cartridges, and canisters used in the workplace are labeled and color coded with the NIOSH- approval label. The label may not be removed and must remain legible.

When selecting respirators, DEL considers the following factors:

- ◆ The classification of the hazard
- ◆ The extent and concentration of the hazard
- ◆ The duration of potential exposure
- ◆ The work requirements and conditions
- ◆ The characteristics and limitations of available respirators
- ◆ A respirator appropriate for the chemical state and physical form of the contaminant is selected from a sufficient number of respirator models and sizes to ensure acceptability and proper fit for the employee. The respirator selected must be adequate to protect the health of the employee during routine and reasonably foreseeable emergency situations.

Respiratory Hazards

- ◆ The classification and extent of respiratory hazards should be verified by monitoring and evaluating potential employee exposure. If the potential respiratory hazards in the workplace include immediately dangerous to life and health (IDLH) atmospheres, one of the following types of respirators must be used:
 - ◆ A full face piece pressure demand SCBA certified by NIOSH for a minimum service life of 30 minutes
 - ◆ A combination full face piece pressure demand SAR with auxiliary self-contained air supply

- ◆ If the potential respiratory hazards in the workplace are gases and vapors that are not IDLH, the Company provides either an atmosphere-supplying respirator or an air-purifying respirator meeting the following criteria:
- ◆ The respirator is equipped with an end of service life indicator (ESLI) certified by NIOSH for the contaminant.
- ◆ If there is no ESLI appropriate for conditions in the workplace, the program administrator implements a change schedule for canisters and cartridges that is based on objective information or data that ensures that canisters and cartridges are changed before the end of their service lives. The program administrator must document and attach to the respirator program the information and data relied on, the basis for the canister and cartridge change schedule, and the basis for reliance on the data.
- ◆ If the potential respiratory hazards in the workplace are particulates that are not IDLH, one of the following types of respirators must be provided and used:
 - An atmosphere-supplying respirator
 - An air-purifying respirator equipped with a filter certified by NIOSH under CFR 30, part 11 as a HEPA filter.
 - An air-purifying respirator equipped with a filter certified for particulates by NIOSH under 42 CFR part 84.
 - For contaminants consisting primarily of particles with mass median aerodynamic diameters (MMAD) of at least 2 micrometers, an air-purifying respirator equipped with any filter certified by NIOSH for particulates.

Medical Evaluations of Employees Required to Use Respirators:

Using a respirator can place a physiological burden on employees that varies with the type of respirator worn, the job and workplace conditions in which the respirator is used, and the medical status of the employee. Accordingly, these are the minimum requirements for medical evaluation that must be implemented to determine an employee's ability to use a respirator before the employee is fit tested or required or allowed to use the respirator in the workplace.

- ◆ A physician or other licensed health care provider (PLHCP) must be selected to perform medical evaluations for each worker. The PLHCP must be provided with a copy of this respiratory protection program and a copy of the OSHA regulation 29 CFR 1910.134 Respiratory Protection.
- ◆ If DEL replaces a PLHCP, DEL must ensure that the new PLHCP receives the program and OSHA information, either by providing the documents directly to the new PLHCP or having the documents transferred from the former PLHCP to the new PLHCP. Employees do not need to be medically reevaluated solely because a new PLHCP has been selected.
- ◆ The PLHCP must perform medical evaluations using an approved program or a medical examination that obtains the same information as Sections 1 and 2, Part A of the OSHA Respirator Medical Evaluation Questionnaire.
- ◆ The questionnaire and examinations must be administered confidentially during the employee's normal working hours or at a time and place convenient to the employee. The questionnaire must be administered so that the employee understands its contents.
- ◆ Company management must provide employees with an opportunity to discuss the questionnaire and examination results with the PLHCP.
- ◆ A follow-up medical examination must be provided for an employee who gives a positive response to any of questions 1 through 8 in Section 2, Part A of the questionnaire or whose initial medical examination demonstrates the need for a follow-up medical examination.
- ◆ The follow-up medical examination includes any medical tests, consultations, or diagnostic procedures that the PLHCP deems necessary to make a final determination.
- ◆ The following information must be provided to the PLHCP before the PLHCP can make a recommendation concerning an employee's ability to use a respirator:

- The type and weight of the respirator to be used by the employee.
- The duration and frequency of respirator use (including use for rescue and escape) The expected physical work effort.
- Additional protective clothing and equipment to be worn.
- Temperature and humidity extremes that might be encountered.
- ◆ DEL must obtain a written recommendation from the PLHCP regarding the employee's ability to use the respirator. The recommendation must provide only the following information:
 - Any limitations on respirator use related to the medical condition of the employee or to the workplace conditions in which the respirator will be used, including whether the employee is medically able to use the respirator. For example, if the respirator is a negative-pressure respirator and the PLHCP finds a medical condition that might place the employee's health at increased risk if the respirator is used, the Company must provide a PAPR, if he PLHCP's medical evaluation finds that the employee can use such a respirator.
 - The need, if any, for follow-up medical evaluations.
 - A statement that the PLHCP has provided the employee with a copy of the written recommendation of the PLHCP.
- ◆ Additional medical evaluations that comply with these requirements must be provided in the event of any of the following:
 - An employee reports medical signs or symptoms that are related to the ability to use a respirator.
 - A PLHCP, supervisor, or the program administrator determines that an employee needs to be reevaluated.
 - Information from this respiratory protection program, including observations made during fit testing and program evaluation, indicates a need for employee reevaluation.
 - A change occurs in workplace conditions (for example, physical work effort, protective clothing, or temperature) that might substantially increase the physiological burden placed on an employee.

Fit Testing Procedures for Tight-Fitting Respirators

- ◆ Before an employee is required or allowed to use any respirator with a negative- or positive-pressure, tight-fitting face piece, the employee must pass an appropriate qualitative fit test (QLFT) or quantitative fit test (QNFT) using the same make, model, style, and size of respirator that will be used at the job site. The QLFT and QNFT must be in accordance with the following guidelines:
 - An employee using a tight-fitting face piece respirator must be fit tested before initial use of the respirator, whenever a different respirator face piece (make, model, style, or size) is used, and at least annually thereafter.
 - Additional fit tests must be conducted whenever the employee reports or the PLHCP, supervisor, or program administrator makes visual observations of changes in the employee's physical condition that could affect respirator fit. Such conditions can include facial scarring, dental changes, cosmetic surgery, or an obvious change in body weight. If after passing a QLFT or QNFT, the employee subsequently notifies the PLHCP, supervisor, or program administrator that the fit of the respirator is unacceptable, the employee is given a reasonable opportunity to select a different respirator face piece and be retested.
 - The fit test must be administered using an OSHA-accepted QLFT or QNFT protocol. QLFT may only be used to fit test negative-pressure air-purifying respirators that must achieve a fit factor of 100 or less.
 - If the fit factor, as determined through an OSHA-accepted QNFT protocol, is equal to or greater than 100 for tight-fitting half face pieces or equal to or greater than 500 for tight fitting full face pieces, the QNFT has been passed with that respirator.
 - Fit testing of tight-fitting atmosphere-supplying respirators and tight-fitting powered air

purifying respirators (PAPR) requires quantitative or qualitative fit testing in the negative-pressure mode, regardless of the mode of operation that is used for respiratory protection.

- Perform qualitative fit testing of these respirators by temporarily converting the face piece of the respirator into a negative-pressure respirator with appropriate filters or by using an identical negative-pressure air-purifying respirator face piece with the same sealing surfaces as a surrogate for the atmosphere-supplying or PAPR face piece.
- Perform quantitative fit testing of these respirators by modifying the face piece to allow sampling inside the face piece in the breathing zone of the user, midway between the nose and mouth. To modify the face piece, install a permanent sampling probe onto a surrogate face piece or use a sampling adapter designed to temporarily provide a means of sampling air from inside the face piece.
- ◆ Any modifications to the respirator face piece for fit testing must be completely removed and the face piece restored to the NIOSH-approved configuration before that face piece can be used in the workplace.

Respirator Maintenance

Each respirator user is provided with a respirator that is clean, sanitary, and in good working order. To clean and disinfect respirators, use the procedures recommended by the respirator manufacturer. When recommendations are not available from the manufacturer, use the following procedures:

- ◆ Remove filters, cartridges, or canisters. Disassemble face pieces by removing speaking diaphragms, demand and pressure demand valve assemblies, hoses, or any components recommended by the manufacturer. Discard or repair any defective parts.
- ◆ Wash components in warm (110 F maximum) water with a mild detergent or with a cleaner recommended by the manufacturer. A stiff bristle (not wire) brush may be used.
- ◆ Rinse components thoroughly in clean, warm, running water. Then drain the water. If the cleaner used in step 2 does not contain a disinfecting agent, immerse the respirator components for two minutes in one of the following substances:
 - Hypochlorite solution made by adding approximately 1 ml of laundry bleach to 1 L of warm water.
 - Aqueous solution of iodine made by adding approximately 0.8 ml of tincture of iodine to 1 L of warm water.
- ◆ Other commercially available cleansers of equivalent disinfectant quality when used as directed if their use is recommended or approved by the respirator manufacturer
- ◆ Rinse components thoroughly in clean, warm, running water. Then drain the water. Thorough rinsing is important because detergents or disinfectants that dry on face pieces can cause dermatitis and some disinfectants can cause rubber to deteriorate or metal parts to corrode if not completely removed.
- ◆ Air dry components or hand-dry them with a clean, lint-free cloth.
- ◆ Reassemble the face piece, replacing filters, cartridges, and canisters where necessary.
- ◆ Test the respirator to ensure that all components work properly. Clean and disinfect respirators at the following intervals:
 - Respirators issued for the exclusive use of an employee: clean and disinfect as often as necessary to maintain a sanitary condition.
 - Respirators issued to more than one employee: clean and disinfect after each use.
 - Respirators maintained for emergency use: clean and disinfect after each use.
 - Respirators used in fit testing and training: clean and disinfect after each use.
- ◆ Store all respirators where they will be protected from damage, contamination, dust, sunlight, extreme temperatures, excessive moisture, and damaging chemicals. Pack respirators in a way that prevents the face piece and exhalation valve from being damaged or deformed.

Emergency respirators must be:

- ◆ Kept accessible to the work area.
- ◆ Stored in containers or covers that are clearly marked as containing emergency respirators.
- ◆ Stored in accordance with any applicable manufacturer instructions.

Respirator Inspections

- ◆ Inspect respirators periodically according to the following instructions:
 - Inspect all respirators used in routine situations before each use and during cleaning.
 - Inspect all respirators maintained for use in emergency situations at least monthly and in accordance with the recommendations of the manufacturer and check them for proper function before and after each use.
 - Inspect emergency escape-only respirators before being carried into the workplace for use.

Respirator inspections must include:

- ◆ A check of respirator function, tightness of connections, and the condition of the various parts, including, but not limited to, the face piece, head straps, valves, connecting tube, cartridges, canisters, or filters.
- ◆ A check of elastomeric parts for pliability and signs of deterioration.
- ◆ Monthly inspections of SCBAs. Air and oxygen cylinders must be maintained in a fully charged state and must be recharged when the pressure falls to 90% of the pressure level recommended by the manufacturer. The regulator and warning devices must function properly.

If respirators are maintained for emergency use, the program administrator must:

- ◆ Certify the respirator by documenting the date the inspection was performed, the name and signature of the person who made the inspection, the findings, the required remedial action, and a serial number or other means of identifying the inspected respirator.
- ◆ Provide this information on a tag or label that is attached to the storage compartment for the respirator, kept with the respirator, or included in inspection reports stored as paper or electronic files.
- ◆ Respirators that fail an inspection or are otherwise found to be defective must be removed from service and discarded, repaired, or adjusted in accordance with the following requirements:
 - Only persons appropriately trained to perform repairs and adjustments, using NIOSH approved parts designed or respirators by the respective manufacturer, are allowed to perform such operations.
 - Repairs must be made according to the recommendations and specifications of the manufacturer for the type and extent of repairs to be performed.
 - Only the manufacturer or technician trained by the manufacturer may adjust or repair reducing admission valves, regulators, and alarms.

Respirators are an effective method of protection against designated hazards when properly selected and worn. Respirator use is encouraged, even when exposures are below the exposure limit, to provide an additional level of comfort and protection for employees. Employees sometimes may wear respirators to avoid exposures to hazards, even if the amount of the hazardous substance does not exceed the limits set

by OSHA standards.

However, if a respirator is used improperly or is not kept clean, the respirator itself can become a hazard. If an employee chooses to wear a respirator for his or her own comfort, the employee must take the following precautions to ensure that the respirator itself does not present a hazard:

- ◆ Read and heed all instructions provided by the manufacturer about the use, maintenance, cleaning and care, and warnings regarding the limitations of the respirator.
- ◆ Choose a respirator that is certified to protect against the contaminant of concern. NIOSH certifies respirators. A label or statement of certification should appear on the respirator or respirator packaging and explain the purpose of and the protection offered by the respirator.
- ◆ Do not wear a respirator into atmospheres containing contaminants against which that respirator is not designed to protect. For example, a respirator designed to filter dust particles will not protect you against gases, vapors, or very small solid particles of fumes or smoke.
- ◆ Do not mistakenly use a respirator that belongs to someone else.

HOT WORK WELDING, BURNING & CUTTING

- ◆ DEL ensures that the safety of all workers, the operations, the company's property, and our customers are considered when performing these operations. This includes, but not limited to:
 - Portable cutting.
 - Welding.
 - Other hot work such as grinding, chipping, and soldering for maintenance, construction, or modifications is done safely.

Definitions.

- ◆ Hot Work: Work producing open flame, sparks or hot flying particles.
- ◆ Safe Work Areas: Areas that have been designated and designed specifically for cutting, welding, grinding or other similar processes.

General Hazards:

- ◆ There are several hazards of concern in welding and cutting. Among these are:
- ◆ Fire from sparks and spatter.
- ◆ Explosions and fires from reactions with welding gases.
- ◆ Asphyxiation.
- ◆ Electrical shock.
- ◆ Inhaling toxic fumes and gases.
- ◆ Eye injuries (foreign bodies and light rays).
- ◆ As with most job hazards, risks of injury can be reduced by following instructions, safety precautions, and by using protective clothing and equipment.

Fire and Explosion:

Fire and explosion are welding and cutting risks. Welding sparks can travel as much as 35 feet, and spatter can bounce on the floor or fall through openings. Methods to minimize the danger are as follows:

- ◆ Weld in separate areas with fire-resistant floors and walls or floor covered with fire-resistant shields.
- ◆ Remove anything that could burn from the area before starting the job.
- ◆ Provide adequate ventilation.
- ◆ Use shields and guards where possible around operations.
- ◆ Stay at least 35 ft. from combustible materials.
- ◆ Do not cut or weld a container unless it has been thoroughly cleaned of anything that could burn, explode, or create toxic vapors.

- ◆ Keep the area clear of trash or debris.
- ◆ If an object and fire hazards cannot be removed, then the guards shall be installed around the object to prevent heat, sparks, and slag from invading immovable fire hazards.
- ◆ Welding and cutting shall not be done in any area where fire hazards cannot be protected.

Gas Welding

- ◆ Check the MSDS of the gas.
- ◆ No smoking.
- ◆ Keep cylinders away from sparks and spatter.
- ◆ Do not run over gas hoses.
- ◆ Do not use oxygen to blow away dust.
- ◆ Use the proper lubricants, not grease or oil, on compressed oxygen cylinder connections.
- ◆ If these conditions cannot be controlled, welding or cutting operations will be stopped until all hazards are controlled.

Inhalation

Welding and cutting operations can create hazardous fumes and gases. In addition to possible respirator use, safety guidelines should be exercised to keep you from inhaling hazardous substances. The use of one of the following should be used:

- ◆ Use ventilation. Mechanical ventilation shall be provided when welding or cutting, if there is less than 10,000 cubic feet per welder, or the overhead height is less than 156 feet.
- ◆ Place fans to the side to blow fumes away from people.
- ◆ Do not get too close to an arc welder's arc.
- ◆ If an employee feels sick, leave the area immediately and seek medical attention.
- ◆ DEL Lead and Cadmium Standards must be followed.

Storage and Handling:

Many welding accidents can occur after the day is complete. They happen because of careless storage and handling. Personnel in charge of welding equipment must be trained and be judged competent to handle the equipment. Follow these precautions:

Arc Welders:

- ◆ Arc welders are electric; follow basic electrical safety practices to prevent shock or electrocution.
- ◆ Use the correct cable size and inspect the insulation.
- ◆ Turn off power before touching electrical parts. Use Lockout/Tag Out procedures.
- ◆ Ground the welding object with a separate electrical connection.
- ◆ Do not wear metal jewelry.
- ◆ Do not weld in the rain.

Gas Welders:

- ◆ Know exactly the contents of a cylinder before it is handled.
- ◆ Read the label or MSDS and follow these general safety guidelines.
- ◆ Keep cylinders upright and properly secured.
- ◆ Store cylinders in dry, ventilated areas away from flammables or heat sources.
- ◆ Check equipment and hoses regularly for leaks, and report any leaking cylinders immediately.
- ◆ Transport cylinders by strapping them to carts.
- ◆ Do not drop or roll a cylinder.
- ◆ Keep valves closed when cylinders are empty or not in use.
- ◆ Light flames promptly according to manufacturer's instructions.
- ◆ Keep cylinders away from heat, sparks, molten metal, etc.

- ◆ Keep oxygen a minimum of 20 feet away from fuel gas cylinders and combustible materials.
- ◆ When transporting cylinder, keep cylinder upright, secured, and at least 20' from a flammable source.

Equipment Safety:

- ◆ Qualified repair persons shall inspect equipment for proper working conditions.
- ◆ Welders should advise repair persons on non-working equipment.
- ◆ Users of the equipment shall report any defects in the equipment to the Site Project Manager.
- ◆ Equipment with defects shall be removed from the site.
- ◆ Repairs shall be made by a qualified person.

Personal Protective Equipment

- ◆ Protective clothing is a very important part of welding and cutting safety. DEL has provided protective equipment for the job. It must be used to keep from being burned or from damaging your eyes.
- ◆ Eye and face protection are vital to safe welding/cutting.
- ◆ DEL Corporation requires:
 - Gas welders to wear impact- and heat-resistant goggles or eye protection
 - Arc welders to wear helmets and eye protection that resist heat, fire, impact, and electricity.
 - Protective clothing is also available from DEL.
 - Wear leather aprons, leggings, and sleeves.
 - Wear long-sleeved shirts with collars and cuffs buttoned.
 - Wear high shoes with pant legs over them.
 - Do not wear anything with cuffs or open pockets that could catch sparks.
 - Wear clean clothes, without grease or oil that could be flammable.
 - Wear flame-resistant head covers.

Hot Work Permit Program.

DEL has instituted this program to establish a procedure for the prevention of fire and explosion when welding, cutting or using spark producing tools. The foreman is to assess the hazards and determine necessary controls (Lockout/Tag Out Procedures, Confined Space Procedures, Personal Protective Equipment, etc.) before any hot work begins.

- ◆ A hot work permit must be issued prior to initiating any hot work in areas containing a hazardous atmosphere, or outside of a designated safe work area. These areas include but are not limited to: crossing existing pipelines, making "Hot" tie-ins, or where the potential exists for there to be an explosive atmosphere.
- ◆ All flammable and combustible materials shall be relocated at least 35 feet from the hot work area or, if relocation is not possible, shall be properly protected by use of fire resistant blankets or similar materials.
- ◆ A first-aid kit shall be immediately available and a minimum of one person on location should be trained and have a valid First Aid/CPR certification.
- ◆ The potential for flammable or combustible liquids, vapors or gases in the area must be eliminated by appropriate means.
- ◆ When performing hot work overhead, the area below must be roped off and posted or otherwise rendered inaccessible to others. Hard hats are required for personnel in these areas.
- ◆ Where possible, noncombustible barriers should be placed around and under the hot work area to confine sparks.
- ◆ A fire watch must be posted whenever hot work is conducted.
- ◆ Appropriate respiratory protection equipment shall be available if necessary.

Fire Watch

- ◆ The foreman should monitor the work and surrounding exposed areas for fire and smoke. If fire or smoke is noted, the foreman should summon aid (911 or appropriate fire emergency number). If the foreman can effect extinguishments without endangering himself/herself or others, the attempt should be made with the provided extinguisher. If this is not possible or if the structure is involved, the foreman and others should evacuate to their assigned areas. Employees are not required or encouraged to engage in the hazardous occupation of firefighting.
- ◆ Hot work in confined spaces will only be permitted when the space can be suitably purged and ventilated to eliminate the possibility of a hazardous atmosphere. A Permit-Required Confined Space Entry Procedures will apply.
- ◆ Fire watches are required in locations where there is potential that a minor fire may develop.
- ◆ Fire watches are required in areas with combustible materials within 35' of the welding operation, areas of wall openings, areas where combustible materials exist.
- ◆ Fire extinguishers shall be readily available in the fire watch areas.
- ◆ A fire watch shall be maintained at least 1 hour after welding and cutting has ceased.
- ◆ Fire watches are required in confined spaces in addition to life lines, gas cylinder safety and posting warning signs. DEL Confined Space Program rules must be followed.

First Aid

- ◆ DEL Safety Program on First Aid shall apply.
- ◆ Whenever there is a welding and cutting operation, first aid equipment must be readily available.
- ◆ Phone numbers of local emergency facilities must be available also.

ABRASIVE WHEEL CUTTING AND GRINDING

Abrasive wheel used for cutting and grinding shall only be used for the purpose in which they were designed including but not limited to the following requirements:

- ◆ The tool and disc must be inspected and in good operating condition before it is put into use, AND worn/defective discs/wheels must be replaced immediately.
- ◆ All guards and safety devices must be on the tool in the correct manner as prescribed by the manufacturer. GUARDS ARE NOT TO BE MODIFIED AND/OR CUT DOWN.
- ◆ The correct disc (proper speed requirements and material), must be used for the tool in which it was intended and shall be appropriate for the task being performed.
- ◆ While using an abrasive wheel for cutting and grinding the user shall wear the following personal Protective equipment:
 - Proper work attire as prescribed before.
 - Leather or other non-flammable gloves.
 - Safety Glasses with side shields that fit tight to the face.
 - A clear face shield adjusted to provide good directional protection for flying debris

TRAFFIC CONTROL SIGNAGE AND BARRIERS

- ◆ Signage and Flagging Shall comply with all DOT, State and Local guidelines for signage and protective systems for worker protection and protection of the public.
- ◆ Retro reflective signs shall be used at all times to assure motorist see the signage and its warning.
- ◆ High visibility clothing must be worn on the right-of-way and at all highway/street crossings unless otherwise specified.
- ◆ Proper signage and flag-persons must be utilized at road crossings as required. Buffer zones are to be established in accordance to the speed of traffic, and Stop/Slow paddles are to be 24" x 24" and of reflective material
- ◆ Pedestrians must be protected/guarded from exposure to the hazards associated with our work at all

times.

- ◆ No trenches are to be left open overnight unless they are guarded (preferably with orange safety fence).
- ◆ Pedestrian and public traffic areas must be protected from the hazards associated with overhead work.

LOCATING AND CROSSING UNDERGROUND FOREIGN UTILITIES

- ◆ A person knowledgeable of the various applicable government rules will perform a pre-job survey to assure all underground utility locations are clearly marked and day lighted (pot holed).
- ◆ Be sure all personnel are aware underground utilities.
- ◆ Have spotter in place with air horn to alert operator if they are digging too close to utilities
- ◆ Use probe rod to maintain knowledge of utility depth.
- ◆ Ensure that excavator has bar placed across teeth
- ◆ Begin hand excavating once equipment is within 2 feet of foreign utility if utility is not already exposed
- ◆ If utility is exposed, follow the respective owner company's minimum clearance requirements, if utility owner has no distance specified; maintain a minimum of 2 feet clearance with mechanical equipment.
- ◆ Ensure that an owner company representative is on site during excavation
- ◆ Keep in contact with the operators at all times.
- ◆ Positive I.D. of all personnel in area prior to moving trucks, equipment and materials
- ◆ Ensure proper sloping or shoring is in place prior to any person entering into an excavation
- ◆ Ensure that proper forms of access and egress are in place prior to workers entering into excavations.

CHAINSAW TREE FELLING

- ◆ Each chainsaw operator shall wear ALL required personal protective equipment (PPE) at all times during chainsaw use. All equipment, including chainsaws and PPE, shall be maintained and inspected before each use to ensure all safety features are in place and functioning properly. Chainsaw cutters are sharp and can cut even if the saw is not running. At full throttle, the chain speed can reach 45 MPH. Reactive forces such as kickback can be dangerous and happen in a fraction of a second
- ◆ The chain saw shall be operated and adjusted in accordance with the manufacturer's instructions
- ◆ Each chain saw shall be equipped with a chain brake to minimize chain-saw kickback. No chainsaw kickback device shall be removed or otherwise disabled.
- ◆ Each gasoline-powered chain saw shall be equipped with a continuous pressure throttle control system which will stop the chain when pressure on the throttle is released.
- ◆ Before cutting each tree and with each work area change during the day, every cutter shall utilize the Hazards, Obstacles, Plan, Execute. (HOPE) procedure in conjunction with the JSA process before starting work. Identify job site hazards, locate all obstacles trees may fall on, plan your work to safely mitigate these hazards and obstacles, execute your plan. This process must be repeated as often as necessary as work areas and conditions change.
- ◆ Get help when necessary to drop difficult trees. Large trees, leaning trees, dead trees, etc., may require roping, wedges, or machinery to get them down safely.
- ◆ All personnel cutting trees shall work safe distances apart by always being at least twice the height of the trees they are cutting in distance from each other.
- ◆ The following PPE is required for safe operation:
 - CSA Type II Hard hats with face shield.
 - Hearing Protection.
 - Saw chaps.
 - Gloves.
 - ANSI approved safety glasses High visibility vest/jacket

Climbing:

- ◆ A pre-climb inspection for possible hazards must be performed by the climber before entering the tree. This must include a visual assessment of the tree and the root collar of the tree
- ◆ Arborists must be tied in or secured while ascending into the tree and remain tied in or secured until the work is completed and they are back on the ground.
- ◆ Climbers must have a minimum of two means of being secured while aloft.
- ◆ A figure-eight knot must be used on the end of the climbing line when working higher than one-half (1/2) the length of the climbing line. Additional figure-eight knots should be used on the tail end of the climbing knot and between the rope snap and climbing knot.
- ◆ A second arborist or tree worker trained in emergency procedures must be within visual or voice communications during arboricultural operations above twelve (12) feet.
- ◆ Arborists must inspect climbing lines, work lines, lanyards, and other climbing equipment for damage, cuts, abrasion and/or deterioration before each use and must remove it from service if signs of excessive wear or damage are found.
- ◆ Hands and feet should be placed on separate limbs, if possible, maintaining three points of contact with the tree while climbing.

Pruning and Trimming

- ◆ Communications must be established between the arborist aloft and the arborists and others on the ground before cutting and dropping limbs. The command "stand clear" from aloft and the response "all clear" from the ground are terms that may be used for this purpose. Prearranged hand signals may also be used. Arborists and other workers returning to the work area must be acknowledged by arborists aloft.
- ◆ A separate work line must be attached to limbs that cannot be dropped safely or controlled by hand.
- ◆ Arborist climbing lines and work lines must not be secured to the same crotch.
- ◆ Cut branches must not be left in trees upon completion of work.

Lowering Limbs:

- ◆ Arborists performing lowering operations must inspect trees to determine if the trees can withstand the strain of lowering procedures. If not, other means of lowering branches must be provided.
- ◆ Arborists in the tree must be above or to the side of the limb being lowered when large limbs are lowered in sections.
- ◆ Work lines must be used when conditions warrant.
- ◆ When large cuts are being made in single-spar trees, both ends of the work positioning lanyard must be attached to a single point on the arborist's saddle to prevent injury should the spar split. The same technique must be used when marking large cuts on large horizontal limbs, which also might split. Hip or side D-rings of the arborist saddle must not be used for this purpose.

Tree Felling/Removal

- ◆ Assess the tree for height, weight distribution, lean, and any hazards in the tree. Pick the direction you would like to drop the tree and look for hazards and obstacles. Once a safe direction of fall is picked, clear your escape route at roughly a 45 degree angle back away from the direction of fall. Make sure your escape route is clear and free of tripping hazards so you can get away from the base of the tree once it begins to fall.
- ◆ Using your chainsaw, cut a notch in the tree with the notch facing the intended direction of fall. Start the notch by making a top cut at a 45-60 degree downward angle to about a depth of 1/3 the diameter of the tree.

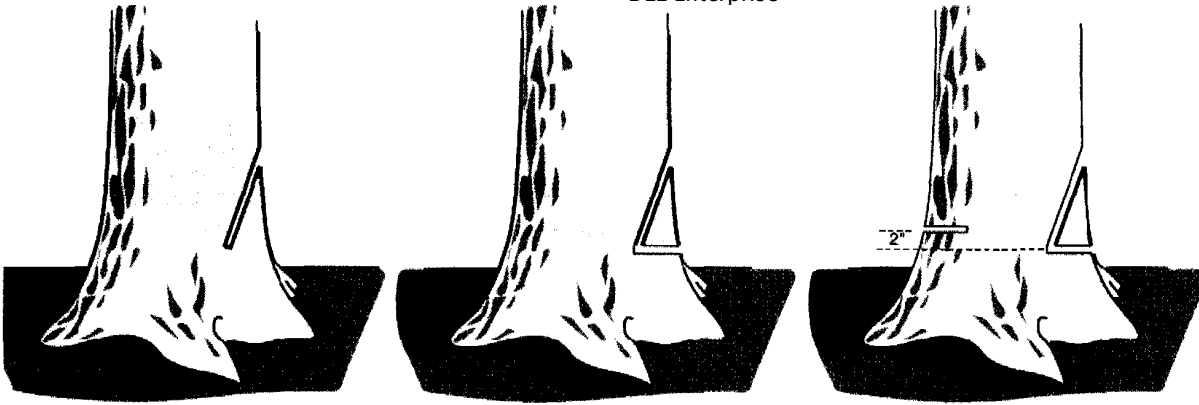

- ◆ Then make a bottom cut for your notch into the tree to exactly meet your top cut. It is important that the two notch cuts meet cleanly to provide a good hinge for the tree to have a controlled fall.
- ◆ The last step in dropping the tree is to make the back cut. Always make the back cut roughly 2" higher than the notch to provide a step for the tree to hinge upon and to prevent the tree from sliding backwards. When making the back cut you should always stand on the opposite side of the lean of the tree and make the cut slowly to leave a good uncut hinge about 10 percent of the diameter of the tree in thickness. DO NOT cut all the way through the tree! This hinge is critical to control the tree while it is falling and to prevent it from falling in the wrong direction.
- ◆ Once the tree is on the ground assess the tree to make sure it is stable and identify bent branches or areas of the trunk that may have strain on them. Then you may limb and buck the tree if necessary, taking care to avoid any bent areas until you can reach them safely and use proper chainsaw techniques to cut them.
- ◆ To cut bent areas safely always stand away from the direction of force. Make a small top cut on the inside of the curve and then slowly cut the back of the curve to relieve any stress until the branch breaks off.

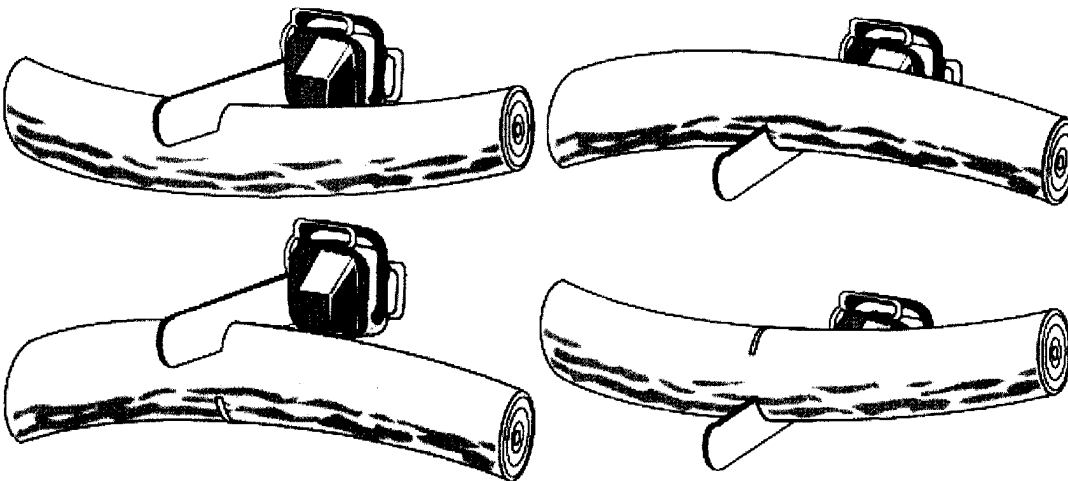

Downward Bend

Upward Bend

- ◆ Once the tree is cut into workable sections, proceed to the next tree, repeating these steps. It is important to assess EVERY tree and drop area for hazards BEFORE cutting.

Brush Removal and Chipping

- ◆ Brush and logs must not be allowed to create hazards in the work areas.
- ◆ Brush and logs must be fed into chippers, butt or cut end first from the side of the feed table center line, and the operator must immediately turn away from the feed table when the brush is taken into the rotor or feed rollers. Chippers must be fed from the curbside whenever practical.
- ◆ The brush chipper discharge chute or cutter housing cover must not be raised or removed while any part of the chipper is turning or moving. Chippers must not be used unless a discharge chute of sufficient length or design is provided that prevents personal contact with the blades.
- ◆ Foreign material, such as stones, nails, sweepings, and takings, must not be fed into chippers.
- ◆ Lose clothing, climbing equipment, body belts or gauntlet-type (long cuffed lineman or welder) gloves must not be worn while operating chippers.
- ◆ Small branches must be fed into chippers with longer branches or by utilizing a long stick for pushing.
- ◆ Hands or other parts of the body must not be placed into the in feed hopper. Leaning into or pushing material into in feed hoppers with feet is prohibited.
- ◆ Training must be provided in the proper operation, feeding, starting and shutdown procedures for the chipper being used.
- ◆ Maintenance must be performed only by those authorized by the employer and trained to perform such operations.

Limbing and Bucking

- ◆ Chain saws must be operated away from the vicinity of the legs and feet. Employ natural barriers where possible, such as limbs between the saw and the body, while ensuring proper balance. While operating a chain saw, the preferred working position is on the uphill side of work.
- ◆ When necessary to prevent rolling, logs must be blocked with wood or other suitable material.
- ◆ Trees, segments of trees, limbs or saplings under stress or tension due to pressure or weight of another object must be considered hazardous. Appropriate cutting techniques must be followed.
- ◆ Wedges must be used as necessary to prevent binding of the guide bar or chain when bucking up trunks of trees.
- ◆ Cant hooks or peaveys must be used as an aid in rolling large or irregular logs to complete bucking.
- ◆ When more than one arborist or other worker is limbing or bucking a tree, each must be aware of the other's location and activity.

SECTION VI: TRAINING

DEL AND SUB-CONTRACTOR TRAINING

Provisions must be implemented for training and communicating Safety and Health programs to all workers involved in this project. We should never assume the worker knows his task thoroughly regardless of his/her experience. Constant reinforcement of the program is required to ensure success.

INDOCTRINATION

Safety policies and general safety rules shall be discussed with all personnel. The site-specific plan is the "starting point" for the training process.

Job Site Analysis Development: The Initial, revisions, Job Site Analysis is a working document, constantly improved upon as the job scope changes. All employees are active participants in the development and improvement with the foremen leading and safety staff technically advising and documenting. (See Section VII)

- ◆ Discuss proper accident reporting procedures and remind workers that **all** accidents, near misses, and/or injuries must be reported to their supervisor immediately.
- ◆ Express interest in safety and impress upon the assigned individual that they are expected to follow safety rules and **WILL BE HELD ACCOUNTABLE IF THEY FAIL TO DO SO.**

SAFETY MEETINGS AND EMERGENCY DRILLS

Safety Meetings:

Employees shall attend and participate in daily tailgate safety meetings by presenting thoughts, ideas, suggestions and comments regarding safe practices and procedures and by providing any knowledge of unsafe conditions or unsafe acts noted in the field. Supervisors shall arrange for employees to attend safety and/or training meetings. The following shall be used, as appropriate, as topics of discussion at safety meetings:

- ◆ Information from the DEL Safety Manual
- ◆ A hazard assessment and its mitigation will be completed daily and whenever scope and hazards change.
- ◆ Potential hazards and precautions associated with different types of operations.
- ◆ Existing hazards and the status of corrective measures.
- ◆ Discussion of accidents from a preventive point of view and not in a way that will embarrass any employee.
- ◆ Other topics pertinent to the operation, as appropriate.

Safety meeting material is available from the Safety Department. A Safety Meeting Roster shall be prepared that summarizes each safety meeting. The summary shall include, but not be limited to, the topics discussed, and the names and signatures of all attendees. The minutes shall be completed accurately. Safety meetings shall be conducted:

- ◆ Once daily, minimum.
- ◆ Prior to the start of normal job duties.
- ◆ Prior to change of duties during normal or other safety sensitive tasks.
- ◆ Prior to any new procedure in operations.
- ◆ Any time management, supervisors, or employees feel it necessary to conduct a safety

meeting.

Tailgate or Other Informal Meetings:

Daily "tailgate meetings" can be held by any employee, but the Supervisor must participate. Questions and discussions are to be encouraged without introducing complaints or other such topics. Tailgate meetings are to be short in duration, approximately 15 minutes. When properly conducted, tailgate meetings give employees an opportunity to reiterate positive, pro-active behaviors that should lead to an incident-free task. Any hazards or unsafe situations should also be addressed during these meetings. This is also a great forum in which to discuss any near-misses and/or incidents and accidents that may have occurred.

EMERGENCY DRILLS

The purpose of conducting emergency drills is to ensure that all employees are proficient in their roles, responsibilities and steps that are to be taken in the event of an emergency. There are two types of exercises that can be utilized in the emergency drill process.

Type 1 -Table-top Drill/Exercise:

- ◆ To be conducted when the project duration will be less than 6 months.
- ◆ Table top drills can be verbally expressed at a general safety meeting to inform all employees of the roles and responsibilities of any involved party.

Type 2 - Field Drill/Exercise:

- ◆ To be conducted when project duration will be between 6 and 12 months.
- ◆ A "Field Drill/Exercise will be conducted with each crew. The leader of that particular crew will physically go through the steps outlined for a given scenario.
- ◆ Scenarios will be developed by the onsite safety department.
- ◆ Field exercises will be evaluated and documented using a go/no go format.
- ◆ Field exercises are to last no longer than 15 minutes.
- ◆ Crew leaders will not receive warning as to when field exercises will take place in an effort to encourage them to maintain a constant plan for each site they move to.

NOTE: When project duration will be greater than 12 months, both the "Table-top Drill/Exercise" and the "Field Exercises" will be conducted. Table-top Drills/Exercises and Field Exercises do not have to be conducted on the same day

Competency Assurance:

It shall be assured that all personnel who are assigned key tasks are deemed competent to perform the tasks properly and safely. This shall be accomplished through the following methods:

- ◆ Short Service Employees Program - As stated previously in this plan a Short Service Employee will be identified and mentored before they are allowed to perform tasks on their own.
- ◆ Documentation from previous training or projects.
- ◆ Any required technical certifications as applicable.
- ◆ As operators are hired and assigned to a respective crew, the foreman of that crew will have a maximum of one week to evaluate the new operator and provide documented feedback as to the competency of the individual's abilities to perform the requested work or operate equipment.

SECTION VII: HAZARD ASSESSMENTS and MITIGATION CONTROLS

Construction Process: ENVIRONMENTAL CREW

Tasks:

Erosion Control, and Dewatering

Hazards:

- ◆ Slips, trips, and falls
- ◆ Poison ivy, oak.
- ◆ Equipment operations - struck by/caught between.
- ◆ Climatic conditions.
- ◆ Spills.
- ◆ Overhead power lines.
- ◆ Underground facilities.
- ◆ Weed control.
- ◆ Fire.
- ◆ Highway traffic.
- ◆ Insects/Snakes.
- ◆ Traffic.

Mitigation Controls:

- ◆ Be aware of surroundings, practice good housekeeping, wear proper footwear with adequate tread, watch for slip, trip and fall hazards along ROW.
- ◆ Plant recognition, P.P.E., Poison Ivy Block, gloves, long sleeve shirts and pants.
- ◆ Stay clear of moving equipment and stay clear of swing radius of equipment. Stay within an operator's vision. Do not ride on equipment unless appropriate seating is available. Be aware of power line proximity.
- ◆ Stay clear of rotating trencher chain.
- ◆ Dress appropriate for weather conditions, water replenishment in heat (20 fluid oz per hour in high heat), warm-up breaks in the cold.
- ◆ Inspect equipment prior to use.
- ◆ Spill kits on equipment and vehicles.
- ◆ Maintain minimum safe clearances (10 feet), use a spotter. Install non-conductive posts and flagging across ROW at the minimum allowable clearance as allowed by regulations for the line voltage (goal posts/warning signs). Beware of atmospheric conditions such as temperature, humidity and wind which may dictate more stringent safety procedures.
- ◆ Ensure one calls are made. Locate all lines and determine the probable depth of the lines to be crossed.
- ◆ Hydro vac or hand-dig to expose critical area to allow for mechanical excavation per Regulations.
- ◆ Existing pipeline(s) and/or cables must be exposed BEFORE commencing mechanical excavation.
- ◆ Ensure proper P.P.E. when spraying. Consult applicable MSDS sheets for further information.
- ◆ Accessible fire extinguishers.

- ◆ Drive defensively, stay alert, adjust speed to suit road/weather conditions, back into parking spaces when practical. Driver and all passengers must wear seat belts whenever the vehicle is in motion.
- ◆ Winter Driving: Ensure snow and ice is cleared from all windows, lights and mirrors. Avoid using cruise control on icy roads. Accelerate and brake gently to avoid skids or spin outs. Ensure fuel tank is kept as full as possible.
- ◆ Check places where snakes may bed up for the night, near warm equipment, pipe, logs, etc. before placing yourself within striking distance. Wear insect repellent and carry an "epi-pen" if you know you are allergic to stings.
- ◆ Ensure that road signs are in place and visible to the public whenever a crew is on site at each road crossing.
- ◆ Whenever equipment is going to be crossing the road, or if vehicles are stopped or parked on the road, flaggers must be in place to control the traffic and protect the workers and public from an accident. If there is no crew on site, the "Flagger Ahead" and the "Be Prepared to Stop" signs must be turned away or covered up to prevent confusion.

Construction Process: LOCATE CREW

Tasks:

Locate foreign crossings while protecting employees from injuries associated with excavating underground utilities.

Hazards:

Slips, trips and falls:

- Poison ivy, oak.
- Equipment operations "Cstruck by/caught between.
- Climatic conditions.
- Spills.
- Overhead power lines.
- Underground facilities.
- Fire.
- Highway travel.
- High pressure water spray on vacuum excavators.
- Traffic.

Mitigation Controls:

- ◆ Be aware of surroundings, practice good housekeeping, wear proper footwear with adequate tread, watch for slip, trip and fall hazards along ROW.
- ◆ Plant recognition, P.P.E., Poison Ivy Block, gloves, long sleeve shirts and pants.
- ◆ Inspect equipment prior to use. Stay clear of moving equipment and stay clear of swing radius on backhoe.
- ◆ Stay within an operator's vision. Do not ride on equipment unless appropriate seating is available. Be aware of power line proximity.
- ◆ Dress appropriate for conditions, water replenishment in heat (20 fluid oz. per hour in high heat), warm-up breaks in the cold weather.
- ◆ Spill kits on equipment and vehicles.
- ◆ Maintain minimum safe clearances (10 feet), install non-conductive posts and flagging across ROW at the minimum allowable clearance as allowed by regulations for the line voltage (goal posts/warning signs). Beware of atmospheric conditions such as temperature, humidity and wind which may dictate more stringent safety procedures.
- ◆ Ensure one calls are made. Locate all lines and determine the probable depth of the lines to be

crossed. Hydro vac or hand-dig to expose critical area to allow for mechanical excavation per Regulations. Existing pipeline(s) and/or cables must be exposed BEFORE commencing mechanical excavation.

- ◆ Adequate fire extinguishers must be readily available.
- ◆ Drive defensively, stay alert, and adjust speed to suit road/weather conditions, back into parking spaces when practical. Driver and all passengers must wear seat belts whenever the vehicle is in motion.
- ◆ Winter Driving: Ensure snow and ice is cleared from all windows, lights and mirrors. Avoid using cruise control on icy roads. Accelerate and brake gently to avoid skids or spin outs. Ensure fuel tank is kept as full as possible.
- ◆ Control spray nozzle. Additional care must be taken when exposing fiberglass lines. Keep all unnecessary personnel and equipment out of the area.
- ◆ Ensure that road signs are in place and visible to the public whenever a crew is on site at each road crossing.
- ◆ Whenever equipment is going to be crossing the road, or if vehicles are stopped or parked on the road, flaggers must be in place to control the traffic and protect the workers and public from an accident. If there is no crew onsite, the "Flagger Ahead" and the "Be Prepared to Stop" signs must be turned away or covered up to prevent confusion.

Construction Process: UTILITY CREW

Tasks:

Build road approaches and install goal posts, road signs, and right-of-way signs to be able access and traverse the right-of way, also to alert the workers and public of the existing construction and electrical hazards.

Hazards:

- ◆ Slips, trips and falls.
- ◆ Poison ivy, oak.
- ◆ Equipment operations-struck by/caught between.
- ◆ Climatic conditions.
- ◆ Spills.
- ◆ Overhead power lines.
- ◆ Underground facilities.
- ◆ Fire.
- ◆ Highway travel.
- ◆ Traffic.

Mitigation Controls:

- ◆ Be aware of surroundings, practice good housekeeping, wear proper footwear with adequate tread, watch for slip, trip and fall hazards along ROW.
- ◆ Plant recognition, P.P.E., Poison Ivy Block, gloves, long sleeve shirts and pants.
- ◆ Inspect equipment prior to use. Stay clear of moving equipment and stay clear of swing radius on backhoe. Stay within an operator's vision. Do not ride on equipment unless appropriate seating is available. Be aware of power line proximity.
- ◆ Dress appropriate for conditions, water replenishment in heat (20 fluid oz. per hour in high heat), warm-up breaks in the cold weather.
- ◆ Spill kits on equipment and vehicles.
- ◆ Use a spotter before goalposts are installed.
- ◆ Maintain minimum safe clearances (10 feet), install non conductive posts and flagging across

ROW at the minimum allowable clearance as allowed by regulations for the line voltage (goal posts/warning signs). Beware of atmospheric conditions such as temperature, humidity and wind which may dictate more stringent safety procedures.

- ◆ Ensure one calls are made. Locate all lines and determine the probable depth of the lines to be crossed. Hydrovac or hand-dig to expose critical area to allow for mechanical excavation as per Regulations. Existing pipeline(s) and/or cables must be exposed BEFORE commencing mechanical excavation.
- ◆ Adequate fire extinguishers must be readily available.
- ◆ Drive defensively, stay alert, adjust speed to suit road/weather conditions, back into parking spaces when practical. Driver and all passengers must wear seatbelts whenever the vehicle is in motion.
- ◆ Winter Driving: Ensure snow and ice is cleared from all windows, lights and mirrors. Avoid using cruise control on icy roads. Accelerate and brake gently to avoid skids or spinouts. Ensure fuel tank is kept as full as possible.
- ◆ Ensure that road signs are in place and visible to the public whenever a crew is on site at each road crossing.

Whenever equipment is going to be crossing the road, or if vehicles are stopped or parked on the road, flaggers must be in place to control the traffic and protect the workers and public from an accident. If there is no crew on site, the "Flagger Ahead" and the "Be Prepared to Stop" signs must be turned away or covered up to prevent confusion.

Construction Process: CLEARING CREW

Tasks:

An order to make the right-of-way a suitable work area, the removal of trees, brush and other vegetation is required.

Hazards:

- ◆ Slips, trips, and falls.
- ◆ Highway travel.
- ◆ Equipment operations - struck by/caught between.
- ◆ Falling timber.
- ◆ Chainsaw use.
- ◆ Poison ivy, oak.
- ◆ Climatic/weather conditions.
- ◆ Spills.
- ◆ Overhead power lines.
- ◆ Underground facilities.
- ◆ Fire.
- ◆ Insects/Snakes.
- ◆ Traffic.

Mitigation Controls:

- ◆ Be aware of surroundings, practice good housekeeping, wear proper footwear with adequate tread, watch for slip, trip and fall hazards along ROW.
- ◆ Drive defensively, stay alert, adjust speed to suit road/weather conditions, back into parking spaces when practical. Driver and all passengers must wear seat belts whenever the vehicle is in motion.
- ◆ Winter Driving: Ensure snow and ice is cleared from all windows, lights and mirrors. Avoid using cruise control on icy roads. Accelerate and break gently to avoid skids or spin outs.

- ◆ Inspect equipment prior to use. Stay clear of moving equipment, watch for flying debris (hydro-ax, chipper etc.). Stay within an operator's vision. Do not ride on equipment unless appropriate seating is available. Never stand between winch and object being removed. Be aware of power line proximity.
- ◆ Know where trees are going to fall and stay clear, watch for falling objects.
- ◆ Inspect chain saw prior to use. Ensure the chain brake is functioning properly and adequately stops the chain. Chain must be sharp and have adequate tension. Watch for kickback and never use saw for cutting above shoulder height. Wear proper P.P.E. (chaps, helmet with screen AND safety glasses). Fueling must be done in a well-ventilated area and NOT while the saw is running or hot.
- ◆ Plant recognition, P.P.E., poison ivy block, gloves, long sleeve shirts and pants.
- ◆ Dress appropriate for conditions, water replenishment in hot weather (20 fluid oz. per hour in high heat), warm-up breaks in the cold weather.
- ◆ Spill kits on equipment and vehicles.
- ◆ Maintain minimum safe clearances (10 feet), install non-conductive posts and flagging across ROW at the minimum allowable clearance as allowed by regulations for the line voltage.
- ◆ Beware of atmospheric conditions such as temperature, humidity and wind which may dictate more stringent safety procedures.
- ◆ Ensure one calls are made. Locate all lines and determine the probable depth of the lines to be crossed. Hydro vac or hand-dig to expose critical area to allow for mechanical excavation as per Regulations. Existing pipeline(s) and/or cables must be exposed BEFORE commencing mechanical excavation.
- ◆ Adequate fire extinguishers must be readily available.
- ◆ Check places where snakes may bed up for the night, near warm equipment, pipe, logs, etc. before placing yourself within striking distance. Wear insect repellent and carry an "epi-pen" if you know you are allergic.
- ◆ Ensure that road signs are in place and visible to the public whenever a crew is on site at each road crossing.
- ◆ Whenever equipment is going to be crossing the road, or if vehicles are stopped or parked on the road, flaggers must be in place to control the traffic and protect the workers and public from an accident. If there is no crew on site, the "Flagger Ahead" and the "Be Prepared to Stop" signs must be turned away or covered up to prevent confusion.

Construction Process: MATTING CREW

Tasks: Transportation and Placement of Timber Mats

Hazards:

- ◆ Slips, trips, and falls.
- ◆ Equipment operations.
- ◆ Climatic conditions.
- ◆ Spills.
- ◆ Overhead power lines.
- ◆ Highway travel.
- ◆ Fire.
- ◆ Load securement.
- ◆ Overhead lifting.
- ◆ Traffic.

Mitigation Controls:

- ◆ Be aware of surroundings, practice good housekeeping, wear proper footwear with adequate tread,

watch for slip, trip, and fall hazards along ROW.

- ◆ Inspect equipment prior to use. Stay clear of moving equipment and stay clear of swing radius of equipment.
- ◆ Stay within an operator's vision. Do not ride on equipment unless appropriate seating's available. Be aware of power line proximity.
- ◆ Dress appropriate for conditions, water replenishment in heat (20 fluid oz. per hour in high heat), warm-up breaks in the cold weather.
- ◆ Spill kits on equipment and vehicles.
- ◆ Maintain minimum safe clearances (10 feet), use a spotter. Install non-conductive posts and flagging across ROW at the minimum allowable clearance as allowed by regulations for the line voltage (goal posts/warning signs). Beware of atmospheric conditions such as temperature, humidity and wind which may dictate more stringent safety procedures.
- ◆ Drive defensively, stay alert, and adjust speed to suit road/weather conditions, back into parking spaces when practical. Driver and all passengers must wear seat belts whenever the vehicle is in motion.
- ◆ Winter Driving: Ensure snow and ice is cleared from all windows, lights and mirrors. Avoid using cruise control on icy roads. Accelerate and brake gently to avoid skids or spin outs. Ensure fuel tank is kept as full as possible.
- ◆ Adequate fire extinguishers must be readily available.
- ◆ Tie-downs in good conditions, mats properly loaded.
- ◆ Stay clear from overhead loads/suspended loads; operator must remain in seat when load is suspended. Keep mats from swinging with tag lines. Check slings and rigging for signs of wear or defects, safety latches on all hooks. Know proper hand signals.
- ◆ Ensure that road signs are in place and visible to the public whenever a crew is onsite at each road crossing.
- ◆ Whenever equipment is going to be crossing the road, or if vehicles are stopped or parked on the road, flaggers must be in place to control the traffic and protect the workers and public from an accident. If there is no crew onsite, the "Flagger Ahead" and the "Be Prepared to Stop" signs must be turned away or covered up to prevent confusion.

Construction Process: R.O.W./GRADING CREW

Tasks: Right of Way Grading, Top Soiling

Hazards:

- ◆ Slips, trips, and falls.
- ◆ Equipment operations struck by/caught between.
- ◆ Climatic conditions.
- ◆ Spills.
- ◆ Overhead power lines.
- ◆ Underground facilities.
- ◆ Highway travel.
- ◆ Fire.
- ◆ Traffic.

Mitigation Controls:

- ◆ Be aware of surroundings, practice good housekeeping, wear proper footwear with adequate tread, watch for slip, trip, and fall hazards along ROW.
- ◆ Inspect equipment prior to use. Stay clear of moving equipment, watch for flying debris (hydro-ax, chipper etc.). Stay within an operator's vision - maintain eye contact with operator. Do not ride on

equipment unless appropriate seating is available. Never stand between winch and object being removed. Be aware of power line proximity.

- ◆ Dress appropriate for conditions, water replenishment in heat (20 fluid oz per hour in high heat), warm-up breaks in the cold weather.
- ◆ Spill kits on equipment and vehicles.
- ◆ Maintain minimum safe clearances (10 feet), use a spotter. Install non-conductive posts and flagging across ROW at the minimum allowable clearance as allowed by regulations for the line voltage (goal posts/warning signs). Beware of atmospheric conditions such as temperature, humidity and wind which may dictate more stringent safety procedures.
- ◆ One-call, hand dig.
- ◆ Drive defensively, stay alert, and adjust speed to suit road/weather conditions, back into parking spaces when practical. Driver and all passengers must wear seatbelts whenever the vehicle is in motion.
- ◆ Winter Driving: Ensure snow and ice is cleared from all windows, lights and mirrors. Avoid using cruise control on icy roads. Accelerate and brake gently to avoid skids or spinouts. Ensure fuel tank is kept as full as possible.
- ◆ Adequate fire extinguishers must be readily available.
- ◆ Ensure that road signs are in place and visible to the public whenever a crew is onsite at each road crossing.
- ◆ Whenever equipment is going to be crossing the road, or if vehicles are stopped or parked on the road, flaggers must be in place to control the traffic and protect the workers and public from an accident. If there is no crew onsite, the "Flagger Ahead" and the "Be Prepared to Stop" signs must be turned away or covered up to prevent confusion.

Construction Process: TRUCKING

Tasks:

Protect workers from injuries associated with trucking operations while equipment or materials are loaded and transported to the pipeline ROW where it is then off-loaded and put into use.

Hazards:

- ◆ Highway travel.
- ◆ Slips, trips, and falls.
- ◆ Pinch points.
- ◆ Overhead lifting.
- ◆ Equipment operations - struck by/caught between & suspended loads.
- ◆ Climatic/weather conditions.
- ◆ Spills.
- ◆ Overhead power lines.
- ◆ Fire.
- ◆ Load Securement.
- ◆ Traffic.

Mitigation Controls:

- ◆ Drive defensively, stay alert, and adjust to conditions. Use caution in city driving, watch for local and pedestrian traffic.
- ◆ Winter Driving: Ensure snow and ice is cleared from all windows, lights and mirrors. Avoid using cruise control on icy roads. Accelerate and brake gently to avoid skids or spin outs. Ensure fuel tank is kept as full as possible.

- ◆ Be aware of surroundings, practice good housekeeping, wear proper footwear with adequate tread, watch for slip, trip and fall hazards along ROW.
- ◆ Keep arms, legs, fingers, toes and all other body parts clear of pinch points at all times. Never reach into a potential pinch point without first taking adequate actions to prevent injury or energy release.
- ◆ Inspect equipment prior to use. Stay clear of moving equipment, stay within an operator's line of vision. Do not ride on equipment unless appropriate seating is available. Stand clear from overhead/suspended loads, operator must remain in seat when load is suspended. Don't get caught in the bight, look out for each other, use tag lines! Know proper hand signals. Be aware of pinch points. Never stand between pipe and equipment OR between the pipe and ditch. Be aware of power line proximity.
- ◆ Inspect equipment prior to use. Stay clear of moving equipment and stay clear of swing radius of equipment.
- ◆ Stay within an operator's vision. Do not ride on equipment unless appropriate seating is available. Be aware of power line proximity, watch for crush points, watch for swing on trailers.
- ◆ Dress appropriate for conditions, water replenishment in heat (20 fluid oz. per hour in high heat), warm-up breaks in the cold weather.
- ◆ Spill kits on equipment and vehicles.
- ◆ Maintain minimum safe clearances (10 feet), install non-conductive posts and flagging across ROW at the minimum allowable clearance as allowed by regulations for the line voltage (goal posts/warning signs). Beware of atmospheric conditions such as temperature, humidity and wind which may dictate more stringent safety procedures.
- ◆ Adequate fire extinguishers must be readily available.
- ◆ Ensure that all loads are properly secured, with adequate straps or certified chains to prevent loads from shifting or coming off.
- ◆ Ensure that road signs are in place and visible to the public whenever a crew is onsite at each road crossing.
- ◆ Whenever equipment is going to be crossing the road, or if vehicles are stopped or parked on the road, flaggers must be in place to control the traffic and protect the workers and public from an accident. If there is no crew onsite, the "Flagger Ahead" and the "Be Prepared to Stop" signs must be turned away or covered up to prevent confusion.

Construction Process: CLEAN UP CREW

Task: Right of Way Restoration

Hazards:

- ◆ Slips.
- ◆ Trips and falls.
- ◆ Equipment operation.
- ◆ Climatic conditions.
- ◆ Overhead power lines.
- ◆ Highway travel.
- ◆ Fire.
- ◆ Spills.
- ◆ Traffic.

Mitigation Controls:

- ◆ Be aware of surroundings, practice good housekeeping, wear proper footwear with adequate tread,

watch for slip, trip and fall hazards along ROW.

- ◆ Inspect equipment prior to use. Stay clear of moving equipment and stay clear of swing radius of equipment.
- ◆ Stay within an operator's vision. Do not ride on equipment unless appropriate seating is available. Be aware of power line proximity, watch for crush points.
- ◆ Dress appropriate for conditions, water replenishment in heat (20 fluid oz per hour in high heat), warm-up breaks in the cold weather.
- ◆ Maintain minimum safe clearances (10 feet), use a spotter. Install non-conductive posts and flagging across ROW at the minimum allowable clearance as allowed by regulations for the line voltage (goal posts/warning signs). Beware of atmospheric conditions such as temperature, humidity and wind which may dictate more stringent safety procedures.
- ◆ Drive defensively, stay alert adjust speed to suit road/weather condition, back into parking spaces when practical. Driver and all passengers must wear seatbelts whenever the vehicle is in motion.
- ◆ Winter Driving: Ensure snow and ice is cleared from all windows, lights and mirrors. Avoid using cruise control on icy roads. Accelerate and brake gently to avoid skids and spin outs. Ensure fuel tank is kept as full as possible.
- ◆ Adequate fire extinguishers must be readily available.
- ◆ Spill kits on equipment and vehicles.
- ◆ Ensure that road signs are in place and visible to the public whenever a crew is onsite at each road crossing.
- ◆ Whenever equipment is going to be crossing the road, or if vehicles are stopped or parked on the road, flaggers must be in place to control the traffic and protect the workers and public from an accident. If there is no crew onsite, the "Flagger Ahead" and the "Be Prepared to Stop" signs must be turned away or covered up to prevent confusion.

Appendix A – Pipeline Restoration Plan

Pipeline Restoration Plan – Prepared by D.E.L. Enterprise staff. Some content used with permission from A. Blackwell and R. Hall, Tetra Tech

The following Restoration Plan was adapted with permission from a guideline by Tetra Tech. It is to be used as a guideline for the successful implementation of grading and re-seeding efforts for our Pipeline Projects.

Introduction

The proposed plan is aimed at improving restoration and seeding efforts to achieve the desired results. The following is comprised of both project requirements and specialized techniques that if followed, will aid in success rates of permanent stabilization of rights-of-way, thereby reducing the need to commit resources to projects months or years after completion.

Soil Sampling

Overview

Collecting soil samples is the first step toward successful final restoration. Proper technique and tools should be used to achieve desired results. At least one sample from each of the three landforms should be submitted for testing and include:

- Active agricultural areas¹
- Pasture land
- Wooded (forest areas)

¹ *Project LOWs supersede soil sample recommendations and may specify specific soil amendments*

Process

Prior to commencement of earth disturbing activities, several samples from each land form should be collected from the topsoil and combined by thorough mixing. One sample from the composite mixture should be submitted for testing. Example: If the project has 10 wooded areas, samples from all ten should be blended together and then a single sample extracted from this mixture would be submitted for testing. This process should be repeated for the number of pasturelands included in the project. Agricultural fields will each be sampled and tested individually, unless the LOWs mandate specific lime, fertilizer and seed mixture application and rates.

Techniques and Equipment

- Probe should be used to obtain a sample from the top eight inches of soil.
- Shovel method may be used if coring tool is not available.
- Station numbers and landform information must be collected.
- Submit samples to laboratory of choice stating seed mixture to be used (this information allows the laboratory to give proper recommendations).

Trench Crowns

Trench subsidence has occurred with some frequency in past projects. There are several factors that lead to this. However, methods such as leaving trench crowns should be used to prevent it. Specifically, employing crowns during backfill should allow for settling before final grade. This negates the need to leave permanent crowns during final restoration. In the event that the contractor, client or EI determines that a permanent crown is warranted, no crowns shall be placed in agricultural fields and breaks in crowns may be required on slopes or long distances to allow for proper water management.

Final Clean Up

Trash Removal

All trash and debris shall be removed from the ROW, including but not limited to:

- Discarded silt fences, stakes, silt sock, geo textile material, etc.
- Survey ribbons and stakes.
- Skids, mat fragments and other construction trash.
- Tree roots, limbs, etc. over 3 inches in diameter shall be removed from wooded areas, with all debris removed from pasturelands and agricultural fields.
- Fabric from silt sock must be removed from the ROW. Fabric and mulch must be removed from agricultural fields.

De-compaction

Travel lane and work area should be de-compacted to a depth of 14 inches. De-compaction of subgrade prior to returning topsoil will reduce the introduction of more rock into the topsoil.

Erosion Control Removal and Reinstallation

Erosion control devices (ECDs) often need to be removed to achieve final grade. Most of the engineered plans, however, state that ECDs are to be left in place until the right-of-way achieves permanent stabilization. Exceptions to adherence with the required plans can be made through consultation with client or the environmental inspectors, otherwise, all ECDs must be reinstalled.

- Water bars and erosion control blankets are not to be installed in active agricultural fields.
- Silt sock in agricultural fields is to be totally removed (mulch and fabric).
- Silt sock in wooded areas can be split, mulch spread, with fabric removed from ROW.
- Silt fence should be removed prior to achieving final grade and then re-installed as required by project documentation or per EI recommendation.
- Silt fence removed from area with no mechanical tillage to follow must have trench properly back filled, seeded and mulched.
- Wooden stakes must be totally removed, not broken off at or above ground level.

Rock Removal

- If rock removal is specified in the ESCP and/or LOW, contractor shall either mechanically or by

hand remove size of rock to the specifications detailed in the purchase order.

- Use of a rock rake and rock picker produces the most desirable seedbed and clean ROW.
- Contractor shall dispose of rock removed in proper manner, ensuring that it is not disposed of in streams or wetlands.

Soil Treatment

- Pulverized agricultural lime and pelletized lime are each acceptable forms to be used at the specified rate.
- Blended fertilizer can be designed by a vendor to, by manipulation of rate per acre, achieve soil sample recommendations and reduce the need for different blends of fertilizer. The goal should be to meet the minimum requirements and possibly exceed on one or two of the nutrients.
- Fertilizer and lime should be applied prior to seed bed preparation. A disk should be used for incorporation, if at all possible, in an effort to incorporate into the top three inches of soil. It is preferred that a drag or harrow be used in conjunction with the disk to help create a more desirable seedbed. If conditions prohibit the use of a disk, a heavy harrow or drag may be substituted with approval from an EI. Several passes may be required to achieve desired seedbed.
- Equipment must be operated in a manner to limit rutting, with no ruts running with grade – only across grade to prevent erosion channels from forming.
- Application should be made by applicator with spinners for even distribution.
- Operators should be knowledgeable of different settings to achieve varying amounts per acre.
- Bulk density of product will be necessary for proper setting of equipment and should be available for EI review.
- Fertilizer and lime must be documented by tract number, date, blend of fertilizer and rate used.

Seeding

Seed Bed Preparation

During seedbed preparation, especially in active agricultural and pastureland, tillage equipment should be operated two to three feet off ROW to help promote smooth transitions. However, whenever working outside the ROW, be sure to have permission from client, EI, or both. There are numerous methods to prepare the seed bed (disk, harrow, etc.). However, our selected method for this project will utilize a bulldozer, trackhoe, and skidsteer/Harley rake, etc.

- Tillage equipment should be operated two to three feet off ROW to help promote smooth transitions between ROW and of ROW. Several passes may be required to aid in blending of contours.
- Medium sized bulldozers (D40D6) should be used to grade the ROW.
- A trackhoe (recommend CAT 320) should be used to move stockpiled topsoil from the edge of the ROW to center, along with other tasks.
- A skidsteer equipped with a large Harley rake, along with other methods, should then go over entire ROW to prepare for seed application.

Seed Application

Drilling and broadcast seeding are acceptable forms of applying seed. If the broadcast method is chosen, seed rate per acre is double that of the drilling method. All seeding must be documented

with seed tags, tract number, planting method and date. Documentation will be turned in daily to EI. There are no exceptions to this documentation process and it applies to streams and wetlands as well. For this project we anticipate using a hydroseeder mounted on a tracked Morooka.

- Drill – a drill can be a traditional style grain drill with disk openers or drill with packer wheels for seed incorporation (i.e. Brillion seeder). Both use metering gates with fluted feeds for accurate distribution of seed.
- Hydro seeding – we must be able to show that desired rates of seed per acre are being achieved by proper calibration of equipment. EI shall verify settings and proper rates.
- Broadcast Seed Incorporation – Seed should be incorporated with harrow to achieve soil to seed contact to help promote emergence. This can be combined with seeding for a single pass or performed separately.
- A form for verification and documentation will be provided for contractor completion and submittal to EI.

Mulching – if and when mulching applies

- Mulching rates are determined by project ESCPs.
- During this and all operations, rutting must be kept to a minimum. If mulching cannot be performed without significant rutting of the ROW, hand mulching will be used as an alternative. During periods of moist, soft conditions, traversing the ROW at angles between water bars is preferred and only across water bars at ends, preferably on the high side. Cutting through water bars is not acceptable. Water bars are a required ECD and will be maintained, if damaged repaired, hand seeded and mulched.
- Mulch must be evenly distributed across the ROW as excess mulch can inhibit seed germination.
- If possible, mulch shall be mechanically anchored to soil surfaces by use of crimping equipment or tracked equipment. Anchoring should not be performed downhill with grade, but at a slight angle to reduce risk of hill erosion.

Rutting

Every consideration should be given to the reduction of ruts on the ROW as it can lead to serious erosion. Equipment should be properly designed to limit rutting as much as possible.

- Tractors and equipment can have dual wheels installed for increased flotation.
- Use rubber tracked equipment.
- Mount hydro seeder on bed of Morooka instead of a trailer to reduce rutting.
- Always cross water bars at the end, preferably at the high side when working in wet conditions.